

Q. 1 – Q. 5 carry one mark each.

Q.1 Which of the following is **CORRECT** with respect to grammar and usage?

Mount Everest is _____.

- (A) the highest peak in the world
- (B) highest peak in the world
- (C) one of highest peak in the world
- (D) one of the highest peak in the world

Q.2 The policeman asked the victim of a theft, “What did you _____?”

- (A) loose
- (B) lose
- (C) loss
- (D) louse

Q.3 Despite the new medicine’s _____ in treating diabetes, it is not _____ widely.

- (A) effectiveness --- prescribed
- (B) availability --- used
- (C) prescription --- available
- (D) acceptance --- proscribed

Q.4 In a huge pile of apples and oranges, both ripe and unripe mixed together, 15% are unripe fruits. Of the unripe fruits, 45% are apples. Of the ripe ones, 66% are oranges. If the pile contains a total of 5692000 fruits, how many of them are apples?

- (A) 2029198
- (B) 2467482
- (C) 2789080
- (D) 3577422

Q.5 Michael lives 10 km away from where I live. Ahmed lives 5 km away and Susan lives 7 km away from where I live. Arun is farther away than Ahmed but closer than Susan from where I live. From the information provided here, what is one possible distance (in km) at which I live from Arun’s place?

- (A) 3.00
- (B) 4.99
- (C) 6.02
- (D) 7.01

Q. 6 – Q. 10 carry two marks each.

Q.6 A person moving through a tuberculosis prone zone has a 50% probability of becoming infected. However, only 30% of infected people develop the disease. What percentage of people moving through a tuberculosis prone zone remains infected but does not show symptoms of disease?

- (A) 15
- (B) 33
- (C) 35
- (D) 37



Q.7 In a world filled with uncertainty, he was glad to have many good friends. He had always assisted them in times of need and was confident that they would reciprocate. However, the events of the last week proved him wrong.

Which of the following inference(s) is/are logically valid and can be inferred from the above passage?

- (i) His friends were always asking him to help them.
- (ii) He felt that when in need of help, his friends would let him down.
- (iii) He was sure that his friends would help him when in need.
- (iv) His friends did not help him last week.

(A) (i) and (ii) (B) (iii) and (iv) (C) (iii) only (D) (iv) only

Q.8 Leela is older than her cousin Pavithra. Pavithra's brother Shiva is older than Leela. When Pavithra and Shiva are visiting Leela, all three like to play chess. Pavithra wins more often than Leela does.

Which one of the following statements must be **TRUE** based on the above?

- (A) When Shiva plays chess with Leela and Pavithra, he often loses.
- (B) Leela is the oldest of the three.
- (C) Shiva is a better chess player than Pavithra.
- (D) Pavithra is the youngest of the three.

Q.9 If $q^{-a} = \frac{1}{r}$ and $r^{-b} = \frac{1}{s}$ and $s^{-c} = \frac{1}{q}$, the value of abc is ____.

(A) $(rqs)^{-1}$ (B) 0 (C) 1 (D) $r+q+s$

Q.10 **P, Q, R** and **S** are working on a project. **Q** can finish the task in 25 days, working alone for 12 hours a day. **R** can finish the task in 50 days, working alone for 12 hours per day. **Q** worked 12 hours a day but took sick leave in the beginning for two days. **R** worked 18 hours a day on all days. What is the ratio of work done by **Q** and **R** after 7 days from the start of the project?

(A) 10:11 (B) 11:10 (C) 20:21 (D) 21:20

END OF THE QUESTION PAPER



Q. 1 – Q. 25 carry one mark each.

Q.1 Let $M^4 = I$, (where I denotes the identity matrix) and $M \neq I$, $M^2 \neq I$ and $M^3 \neq I$. Then, for any natural number k , M^{-1} equals:

- (A) M^{4k+1} (B) M^{4k+2} (C) M^{4k+3} (D) M^{4k}

Q.2 The second moment of a Poisson-distributed random variable is 2. The mean of the random variable is _____

Q.3 Given the following statements about a function $f: \mathbb{R} \rightarrow \mathbb{R}$, select the right option:

P: If $f(x)$ is continuous at $x = x_0$, then it is also differentiable at $x = x_0$.

Q: If $f(x)$ is continuous at $x = x_0$, then it may not be differentiable at $x = x_0$.

R: If $f(x)$ is differentiable at $x = x_0$, then it is also continuous at $x = x_0$.

- (A) P is true, Q is false, R is false (B) P is false, Q is true, R is true
(C) P is false, Q is true, R is false (D) P is true, Q is false, R is true

Q.4 Which one of the following is a property of the solutions to the Laplace equation: $\nabla^2 f = 0$?

- (A) The solutions have neither maxima nor minima anywhere except at the boundaries.
(B) The solutions are not separable in the coordinates.
(C) The solutions are not continuous.
(D) The solutions are not dependent on the boundary conditions.

Q.5 Consider the plot of $f(x)$ versus x as shown below.

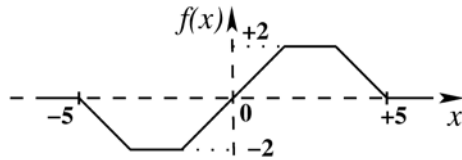

Suppose $F(x) = \int_{-5}^x f(y)dy$. Which one of the following is a graph of $F(x)$?

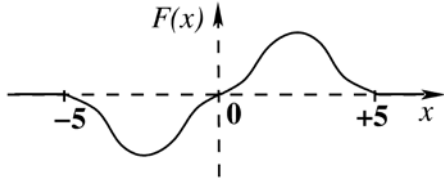

(A)

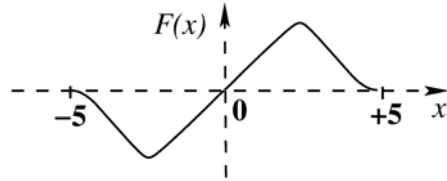

(B)

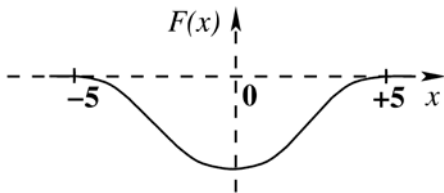

(C)

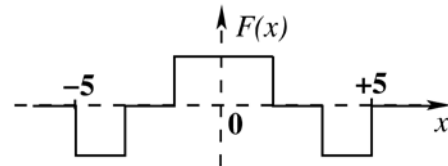

(D)

Q.6 Which one of the following is an eigen function of the class of all continuous-time, linear, time-invariant systems ($u(t)$ denotes the unit-step function)?

(A) $e^{j\omega_0 t} u(t)$

(B) $\cos(\omega_0 t)$

(C) $e^{j\omega_0 t}$

(D) $\sin(\omega_0 t)$

Q.7 A continuous-time function $x(t)$ is periodic with period T . The function is sampled uniformly with a sampling period T_s . In which one of the following cases is the sampled signal periodic?

(A) $T = \sqrt{2} T_s$

(B) $T = 1.2 T_s$

(C) Always

(D) Never

Q.8 Consider the sequence $x[n] = a^n u[n] + b^n u[n]$, where $u[n]$ denotes the unit-step sequence and $0 < |a| < |b| < 1$. The region of convergence (ROC) of the z-transform of $x[n]$ is

(A) $|z| > |a|$

(B) $|z| > |b|$

(C) $|z| < |a|$

(D) $|a| < |z| < |b|$

- Q.9 Consider a two-port network with the transmission matrix: $T = \begin{pmatrix} A & B \\ C & D \end{pmatrix}$. If the network is reciprocal, then
- (A) $T^{-1} = T$ (B) $T^2 = T$
(C) Determinant (T) = 0 (D) Determinant (T) = 1
- Q.10 A continuous-time sinusoid of frequency 33 Hz is multiplied with a periodic Dirac impulse train of frequency 46 Hz. The resulting signal is passed through an ideal analog low-pass filter with a cutoff frequency of 23 Hz. The fundamental frequency (in Hz) of the output is _____
- Q.11 A small percentage of impurity is added to an intrinsic semiconductor at 300 K. Which one of the following statements is true for the energy band diagram shown in the following figure?

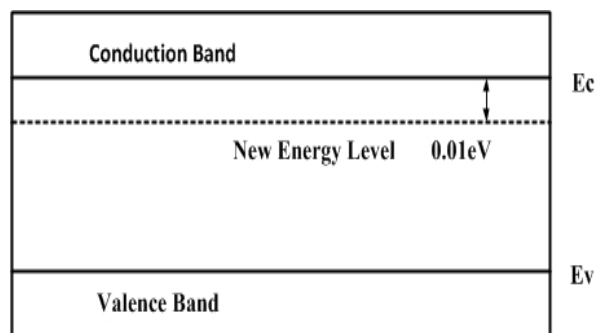

- (A) Intrinsic semiconductor doped with pentavalent atoms to form n -type semiconductor
(B) Intrinsic semiconductor doped with trivalent atoms to form n -type semiconductor
(C) Intrinsic semiconductor doped with pentavalent atoms to form p -type semiconductor
(D) Intrinsic semiconductor doped with trivalent atoms to form p -type semiconductor
- Q.12 Consider the following statements for a metal oxide semiconductor field effect transistor (MOSFET):
- P: As channel length reduces, OFF-state current increases.
Q: As channel length reduces, output resistance increases.
R: As channel length reduces, threshold voltage remains constant.
S: As channel length reduces, ON current increases.
- Which of the above statements are INCORRECT?
- (A) P and Q (B) P and S (C) Q and R (D) R and S

Q.13 Consider the constant current source shown in the figure below. Let β represent the current gain of the transistor.

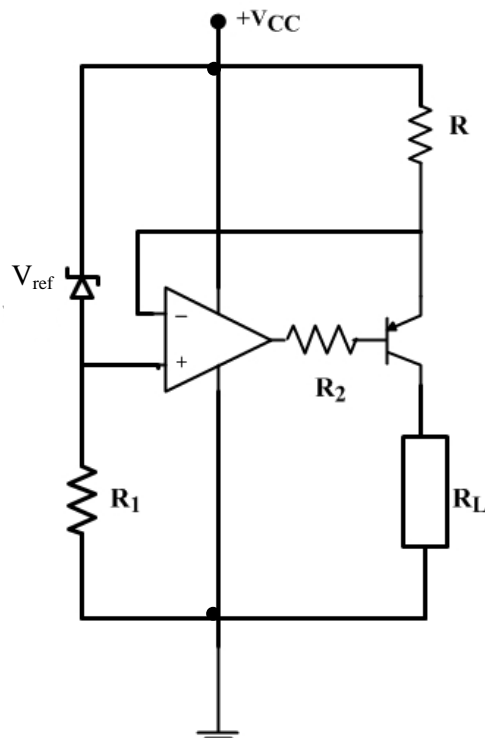

The load current I_0 through R_L is

- (A) $I_0 = \left(\frac{\beta+1}{\beta}\right) \frac{V_{ref}}{R}$ (B) $I_0 = \left(\frac{\beta}{\beta+1}\right) \frac{V_{ref}}{R}$ (C) $I_0 = \left(\frac{\beta+1}{\beta}\right) \frac{V_{ref}}{2R}$ (D) $I_0 = \left(\frac{\beta}{\beta+1}\right) \frac{V_{ref}}{2R}$

Q.14 The following signal V_i of peak voltage 8 V is applied to the non-inverting terminal of an ideal opamp. The transistor has $V_{BE} = 0.7$ V, $\beta = 100$; $V_{LED} = 1.5$ V, $V_{CC} = 10$ V and $-V_{CC} = -10$ V.

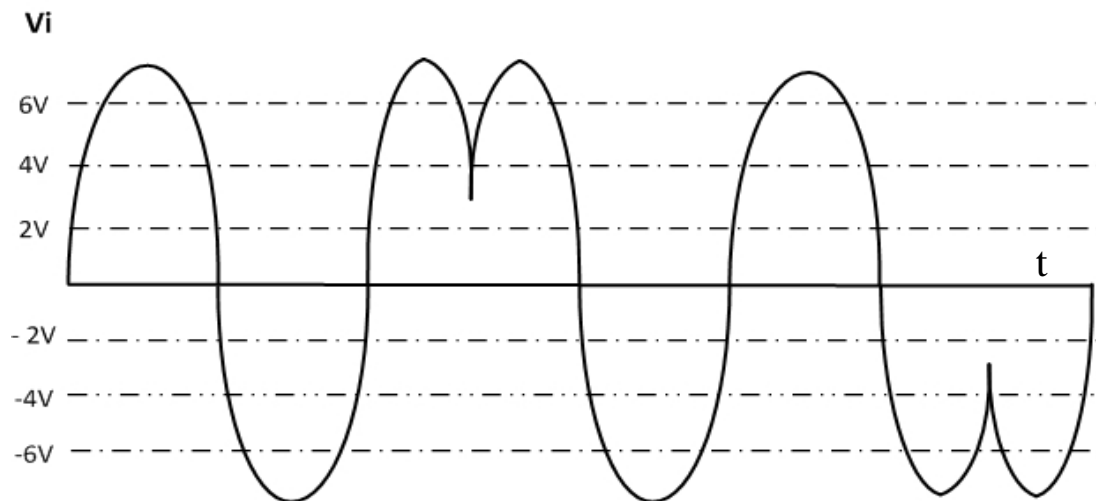
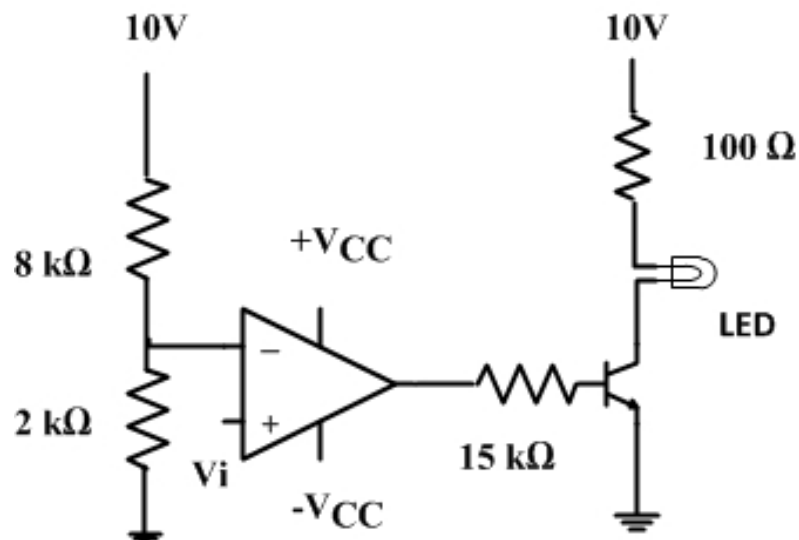

The number of times the LED glows is _____

Q.15 Consider the oscillator circuit shown in the figure. The function of the network (shown in dotted lines) consisting of the $100\text{ k}\Omega$ resistor in series with the two diodes connected back-to-back is to:

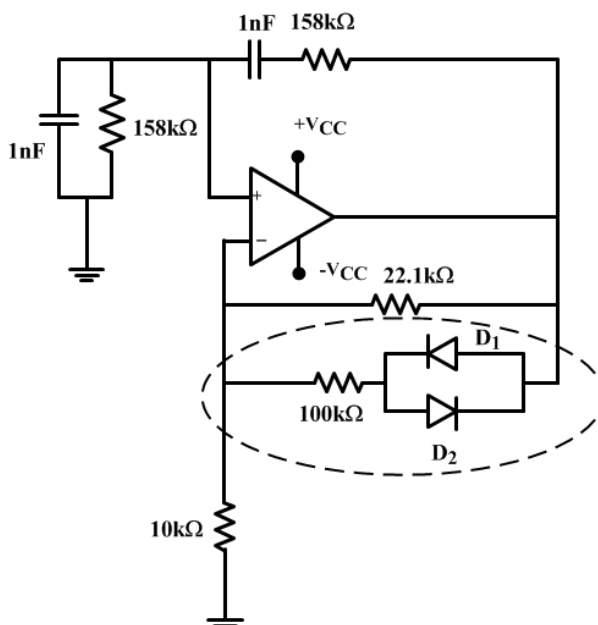

- (A) introduce amplitude stabilization by preventing the op amp from saturating and thus producing sinusoidal oscillations of fixed amplitude
- (B) introduce amplitude stabilization by forcing the opamp to swing between positive and negative saturation and thus producing square wave oscillations of fixed amplitude
- (C) introduce frequency stabilization by forcing the circuit to oscillate at a single frequency
- (D) enable the loop gain to take on a value that produces square wave oscillations

Q.16 The block diagram of a frequency synthesizer consisting of a Phase Locked Loop (PLL) and a divide-by- N counter (comprising $\div 2, \div 4, \div 8, \div 16$ outputs) is sketched below. The synthesizer is excited with a 5 kHz signal (Input 1). The free-running frequency of the PLL is set to 20 kHz. Assume that the commutator switch makes contacts repeatedly in the order 1-2-3-4.

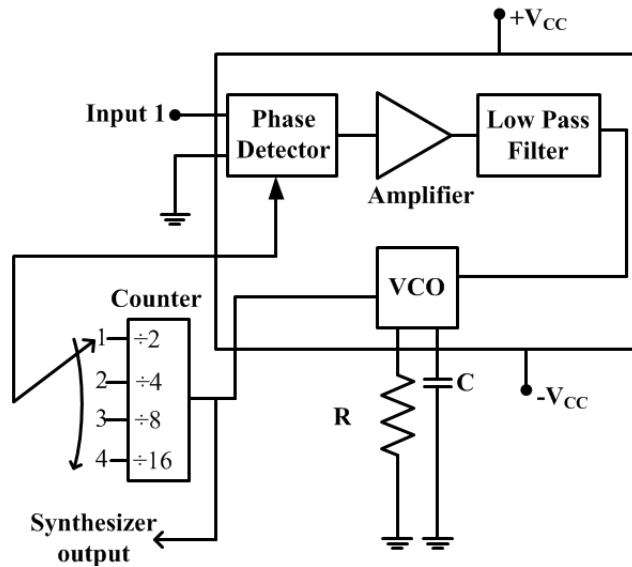

The corresponding frequencies synthesized are:

- (A) 10 kHz, 20 kHz, 40 kHz, 80 kHz
- (B) 20 kHz, 40 kHz, 80 kHz, 160 kHz
- (C) 80 kHz, 40 kHz, 20 kHz, 10 kHz
- (D) 160 kHz, 80 kHz, 40 kHz, 20 kHz

Q.17 The output of the combinational circuit given below is

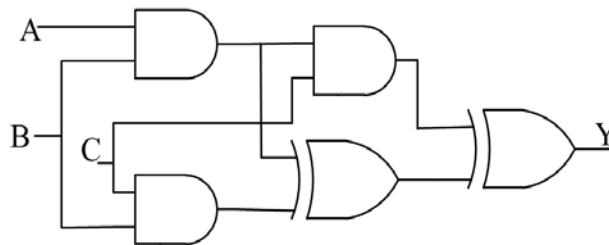

- (A) $A+B+C$
- (B) $A(B+C)$
- (C) $B(C+A)$
- (D) $C(A+B)$

Q.18 What is the voltage V_{out} in the following circuit?

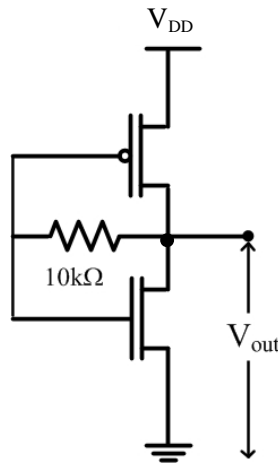

- (A) 0 V
 (B) $(|V_T \text{ of PMOS}| + V_T \text{ of NMOS}) / 2$
 (C) Switching threshold of inverter
 (D) V_{DD}

Q.19 Match the inferences X, Y, and Z, about a system, to the corresponding properties of the elements of first column in Routh's Table of the system characteristic equation.

- | | |
|-------------------------------|---|
| X: The system is stable ... | P: ... when all elements are positive |
| Y: The system is unstable ... | Q: ... when any one element is zero |
| Z: The test breaks down ... | R: ... when there is a change in sign of coefficients |

- (A) $X \rightarrow P, Y \rightarrow Q, Z \rightarrow R$
 (B) $X \rightarrow Q, Y \rightarrow P, Z \rightarrow R$
 (C) $X \rightarrow R, Y \rightarrow Q, Z \rightarrow P$
 (D) $X \rightarrow P, Y \rightarrow R, Z \rightarrow Q$

Q.20 A closed-loop control system is stable if the Nyquist plot of the corresponding open-loop transfer function

- (A) encircles the s -plane point $(-1 + j0)$ in the counterclockwise direction as many times as the number of right-half s -plane poles.
 (B) encircles the s -plane point $(0 - j1)$ in the clockwise direction as many times as the number of right-half s -plane poles.
 (C) encircles the s -plane point $(-1 + j0)$ in the counterclockwise direction as many times as the number of left-half s -plane poles.
 (D) encircles the s -plane point $(-1 + j0)$ in the counterclockwise direction as many times as the number of right-half s -plane zeros.

Q.21 Consider binary data transmission at a rate of 56 kbps using baseband binary pulse amplitude modulation (PAM) that is designed to have a raised-cosine spectrum. The transmission bandwidth (in kHz) required for a roll-off factor of 0.25 is _____

- Q.22 A superheterodyne receiver operates in the frequency range of 58 MHz – 68 MHz. The intermediate frequency f_{IF} and local oscillator frequency f_{LO} are chosen such that $f_{IF} \leq f_{LO}$. It is required that the image frequencies fall outside the 58 MHz – 68 MHz band. The minimum required f_{IF} (in MHz) is _____
- Q.23 The amplitude of a sinusoidal carrier is modulated by a single sinusoid to obtain the amplitude modulated signal $s(t) = 5 \cos 1600\pi t + 20 \cos 1800\pi t + 5 \cos 2000\pi t$. The value of the modulation index is _____
- Q.24 Concentric spherical shells of radii 2 m, 4 m, and 8 m carry uniform surface charge densities of 20 nC/m^2 , -4 nC/m^2 and ρ_s , respectively. The value of ρ_s (nC/m^2) required to ensure that the electric flux density $\vec{D} = \vec{0}$ at radius 10 m is _____
- Q.25 The propagation constant of a lossy transmission line is $(2 + j5) \text{ m}^{-1}$ and its characteristic impedance is $(50 + j0) \Omega$ at $\omega = 10^6 \text{ rad s}^{-1}$. The values of the line constants L, C, R, G are, respectively,
- (A) $L = 200 \mu\text{H/m}$, $C = 0.1 \mu\text{F/m}$, $R = 50 \Omega/\text{m}$, $G = 0.02 \text{ S/m}$
 (B) $L = 250 \mu\text{H/m}$, $C = 0.1 \mu\text{F/m}$, $R = 100 \Omega/\text{m}$, $G = 0.04 \text{ S/m}$
 (C) $L = 200 \mu\text{H/m}$, $C = 0.2 \mu\text{F/m}$, $R = 100 \Omega/\text{m}$, $G = 0.02 \text{ S/m}$
 (D) $L = 250 \mu\text{H/m}$, $C = 0.2 \mu\text{F/m}$, $R = 50 \Omega/\text{m}$, $G = 0.04 \text{ S/m}$

Q. 26 – Q. 55 carry two marks each.

- Q.26 The integral $\frac{1}{2\pi} \iint_D (x + y + 10) dx dy$, where D denotes the disc: $x^2 + y^2 \leq 4$, evaluates to _____
- Q.27 A sequence $x[n]$ is specified as
- $$\begin{bmatrix} x[n] \\ x[n-1] \end{bmatrix} = \begin{bmatrix} 1 & 1 \\ 1 & 0 \end{bmatrix}^n \begin{bmatrix} 1 \\ 0 \end{bmatrix}, \text{ for } n \geq 2.$$
- The initial conditions are $x[0] = 1$, $x[1] = 1$, and $x[n] = 0$ for $n < 0$. The value of $x[12]$ is _____
- Q.28 In the following integral, the contour C encloses the points $2\pi j$ and $-2\pi j$
- $$-\frac{1}{2\pi} \oint_C \frac{\sin z}{(z - 2\pi j)^3} dz$$
- The value of the integral is _____
- Q.29 The region specified by $\{(\rho, \varphi, z): 3 \leq \rho \leq 5, \frac{\pi}{8} \leq \varphi \leq \frac{\pi}{4}, 3 \leq z \leq 4.5\}$ in cylindrical coordinates has volume of _____

Q.30 The Laplace transform of the causal periodic square wave of period T shown in the figure below is

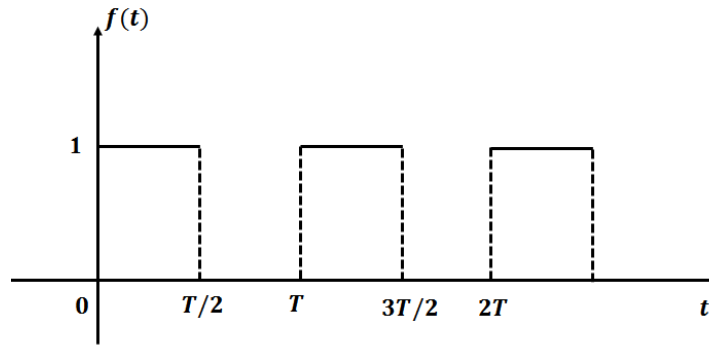

(A) $F(s) = \frac{1}{1+e^{-sT/2}}$

(B) $F(s) = \frac{1}{s(1+e^{-\frac{sT}{2}})}$

(C) $F(s) = \frac{1}{s(1-e^{-sT})}$

(D) $F(s) = \frac{1}{1-e^{-sT}}$

Q.31 A network consisting of a finite number of linear resistor (R), inductor (L), and capacitor (C) elements, connected all in series or all in parallel, is excited with a source of the form

$$\sum_{k=1}^3 a_k \cos(k\omega_0 t), \text{ where } a_k \neq 0, \omega_0 \neq 0.$$

The source has nonzero impedance. Which one of the following is a possible form of the output measured across a resistor in the network?

(A) $\sum_{k=1}^3 b_k \cos(k\omega_0 t + \phi_k), \text{ where } b_k \neq a_k, \forall k$

(B) $\sum_{k=1}^4 b_k \cos(k\omega_0 t + \phi_k), \text{ where } b_k \neq 0, \forall k$

(C) $\sum_{k=1}^3 a_k \cos(k\omega_0 t + \phi_k)$

(D) $\sum_{k=1}^2 a_k \cos(k\omega_0 t + \phi_k)$

Q.32 A first-order low-pass filter of time constant T is excited with different input signals (with zero initial conditions up to $t = 0$). Match the excitation signals X, Y, Z with the corresponding time responses for $t \geq 0$:

X: Impulse

P: $1 - e^{-t/T}$

Y: Unit step

Q: $t - T(1 - e^{-t/T})$

Z: Ramp

R: $e^{-t/T}$

(A) X→R, Y→Q, Z→P

(B) X→Q, Y→P, Z→R

(C) X→R, Y→P, Z→Q

(D) X→P, Y→R, Z→Q



Q.33 An AC voltage source $V = 10 \sin(t)$ volts is applied to the following network. Assume that $R_1 = 3 \text{ k}\Omega$, $R_2 = 6 \text{ k}\Omega$ and $R_3 = 9 \text{ k}\Omega$, and that the diode is ideal.

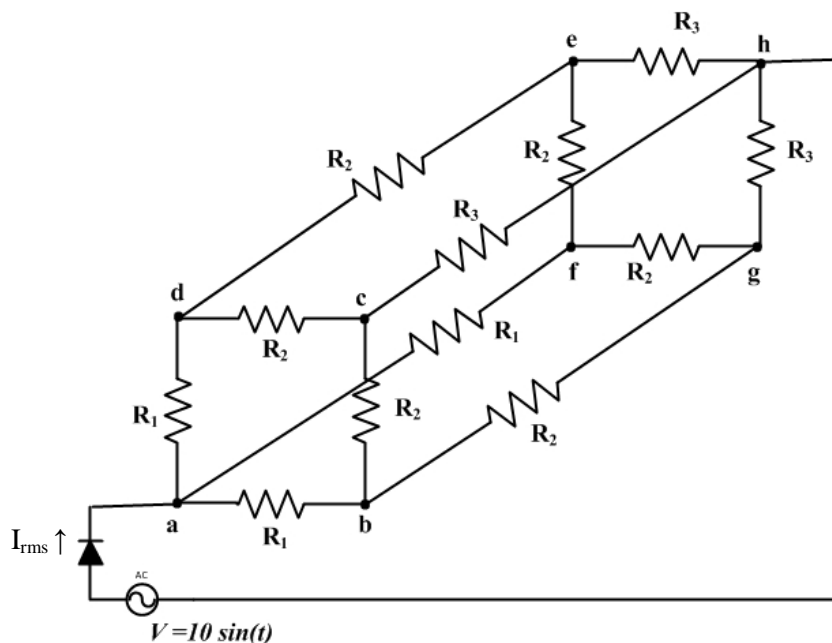

RMS current I_{rms} (in mA) through the diode is _____

Q.34 In the circuit shown in the figure, the maximum power (in watt) delivered to the resistor R is _____

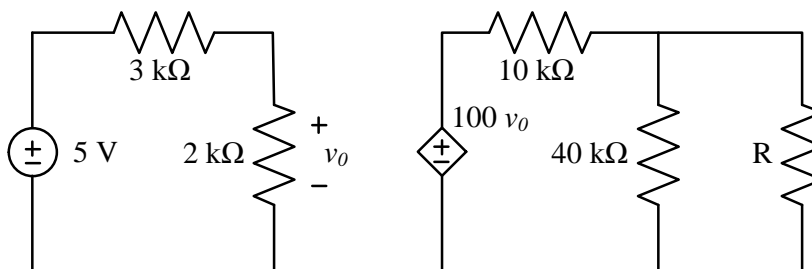

Q.35 Consider the signal

$$x[n] = 6 \delta[n + 2] + 3 \delta[n + 1] + 8 \delta[n] + 7 \delta[n - 1] + 4 \delta[n - 2]$$

If $X(e^{j\omega})$ is the discrete-time Fourier transform of $x[n]$,

then $\frac{1}{\pi} \int_{-\pi}^{\pi} X(e^{j\omega}) \sin^2(2\omega) d\omega$ is equal to _____

Q.36 Consider a silicon p-n junction with a uniform acceptor doping concentration of 10^{17} cm^{-3} on the p-side and a uniform donor doping concentration of 10^{16} cm^{-3} on the n-side. No external voltage is applied to the diode. Given: $kT/q = 26 \text{ mV}$, $n_i = 1.5 \times 10^{10} \text{ cm}^{-3}$, $\epsilon_{\text{Si}} = 12\epsilon_0$, $\epsilon_0 = 8.85 \times 10^{-14} \text{ F/m}$, and $q = 1.6 \times 10^{-19} \text{ C}$.
The charge per unit junction area (nC cm^{-2}) in the depletion region on the p-side is _____

Q.37 Consider an n-channel metal oxide semiconductor field effect transistor (MOSFET) with a gate-to-source voltage of 1.8 V. Assume that $\frac{W}{L} = 4$, $\mu_N C_{ox} = 70 \times 10^{-6} \text{ AV}^{-2}$, the threshold voltage is 0.3V, and the channel length modulation parameter is 0.09 V^{-1} . In the saturation region, the drain conductance (in micro seimens) is _____

Q.38 The figure below shows the doping distribution in a p-type semiconductor in log scale.

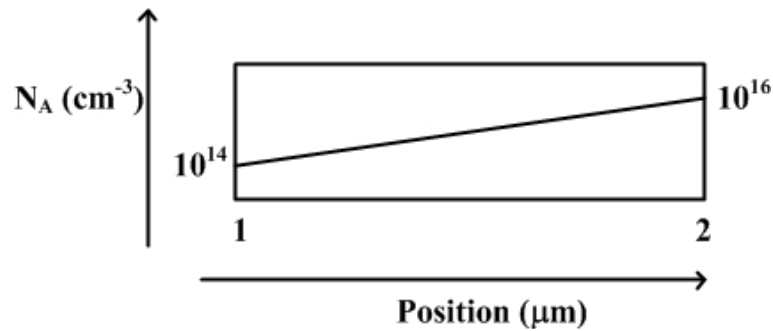

The magnitude of the electric field (in kV/cm) in the semiconductor due to non uniform doping is _____

Q.39 Consider a silicon sample at $T = 300 \text{ K}$, with a uniform donor density $N_d = 5 \times 10^{16} \text{ cm}^{-3}$, illuminated uniformly such that the optical generation rate is $G_{opt} = 1.5 \times 10^{20} \text{ cm}^{-3} \text{ s}^{-1}$ throughout the sample. The incident radiation is turned off at $t = 0$. Assume low-level injection to be valid and ignore surface effects. The carrier lifetimes are $\tau_{p0} = 0.1 \mu\text{s}$ and $\tau_{n0} = 0.5 \mu\text{s}$.

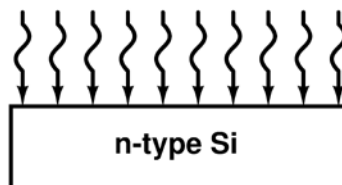

The hole concentration at $t = 0$ and the hole concentration at $t = 0.3 \mu\text{s}$, respectively, are

- (A) $1.5 \times 10^{13} \text{ cm}^{-3}$ and $7.47 \times 10^{11} \text{ cm}^{-3}$
- (B) $1.5 \times 10^{13} \text{ cm}^{-3}$ and $8.23 \times 10^{11} \text{ cm}^{-3}$
- (C) $7.5 \times 10^{13} \text{ cm}^{-3}$ and $3.73 \times 10^{11} \text{ cm}^{-3}$
- (D) $7.5 \times 10^{13} \text{ cm}^{-3}$ and $4.12 \times 10^{11} \text{ cm}^{-3}$

Q.40 An ideal opamp has voltage sources $V_1, V_3, V_5, \dots, V_{N-1}$ connected to the non-inverting input and $V_2, V_4, V_6, \dots, V_N$ connected to the inverting input as shown in the figure below ($+V_{CC} = 15$ volt, $-V_{CC} = -15$ volt). The voltages $V_1, V_2, V_3, V_4, V_5, V_6, \dots$ are $1, -1/2, 1/3, -1/4, 1/5, -1/6, \dots$ volt, respectively. As N approaches infinity, the output voltage (in volt) is _____

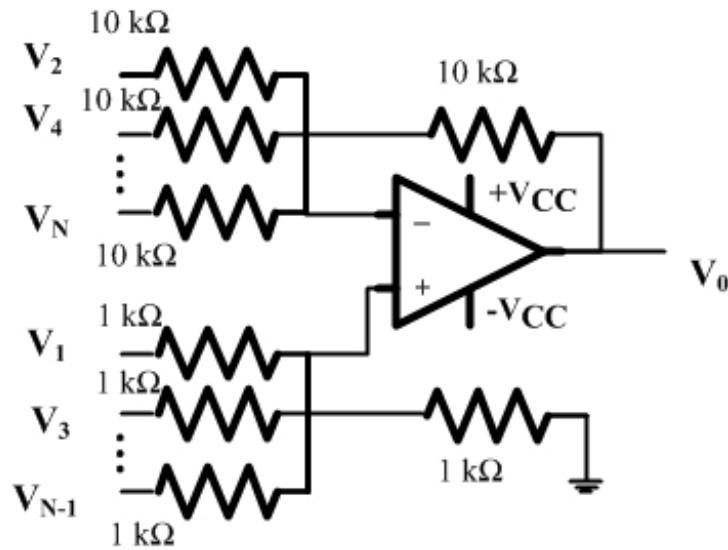

Q.41 A $p-i-n$ photodiode of responsivity 0.8A/W is connected to the inverting input of an ideal opamp as shown in the figure, $+V_{CC} = 15\text{ V}$, $-V_{CC} = -15\text{V}$, Load resistor $R_L = 10\text{ k}\Omega$. If $10\text{ }\mu\text{W}$ of power is incident on the photodiode, then the value of the photocurrent (in μA) through the load is _____

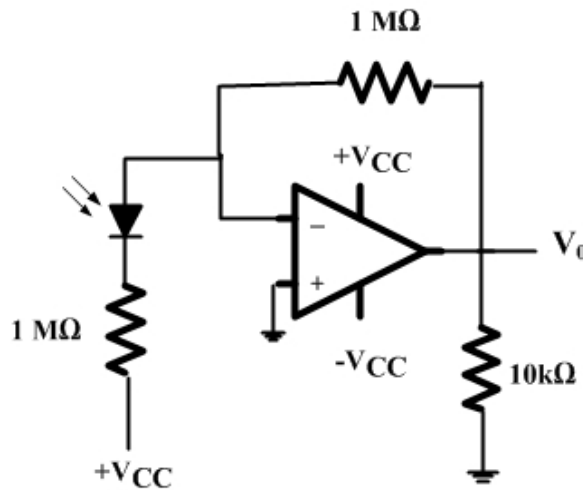

Q.42 Identify the circuit below.

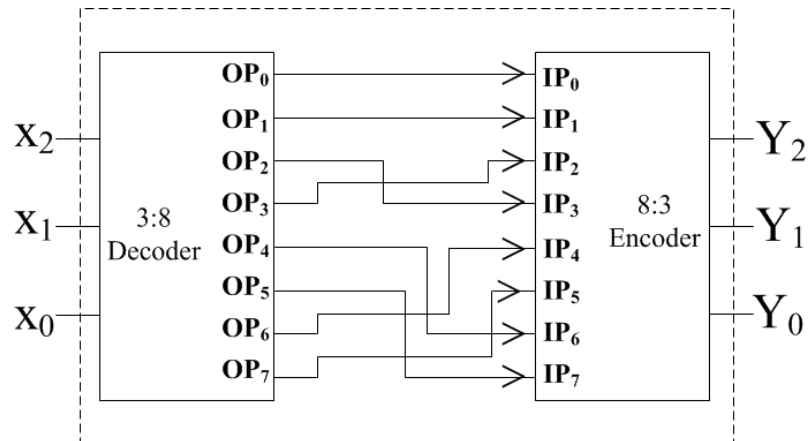

- (A) Binary to Gray code converter
- (B) Binary to XS3 converter
- (C) Gray to Binary converter
- (D) XS3 to Binary converter

Q.43 The functionality implemented by the circuit below is

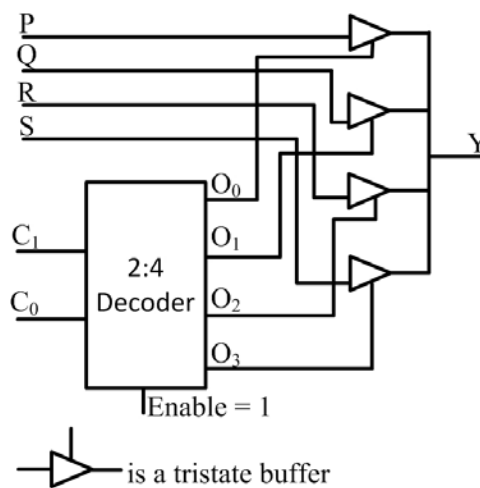

- (A) 2-to-1 multiplexer
- (B) 4-to-1 multiplexer
- (C) 7-to-1 multiplexer
- (D) 6-to-1 multiplexer

Q.44 In an 8085 system, a PUSH operation requires more clock cycles than a POP operation. Which one of the following options is the correct reason for this?

(A) For POP, the data transceivers remain in the same direction as for instruction fetch (memory to processor), whereas for PUSH their direction has to be reversed.

(B) Memory write operations are slower than memory read operations in an 8085 based system.

(C) The stack pointer needs to be pre-decremented before writing registers in a PUSH, whereas a POP operation uses the address already in the stack pointer.

(D) Order of registers has to be interchanged for a PUSH operation, whereas POP uses their natural order.

Q.45 The open-loop transfer function of a unity-feedback control system is

$$G(s) = \frac{K}{s^2 + 5s + 5}$$

The value of K at the breakaway point of the feedback control system's root-locus plot is _____

Q.46 The open-loop transfer function of a unity-feedback control system is given by

$$G(s) = \frac{K}{s(s + 2)}$$

For the peak overshoot of the closed-loop system to a unit step input to be 10%, the value of K is _____

Q.47 The transfer function of a linear time invariant system is given by

$$H(s) = 2s^4 - 5s^3 + 5s - 2$$

The number of zeros in the right half of the s -plane is _____

Q.48 Consider a discrete memoryless source with alphabet $S = \{s_0, s_1, s_2, s_3, s_4, \dots\}$ and respective probabilities of occurrence $P = \left\{\frac{1}{2}, \frac{1}{4}, \frac{1}{8}, \frac{1}{16}, \frac{1}{32}, \dots\right\}$. The entropy of the source (in bits) is _____

Q.49 A digital communication system uses a repetition code for channel encoding/decoding. During transmission, each bit is repeated three times (0 is transmitted as 000, and 1 is transmitted as 111). It is assumed that the source puts out symbols independently and with equal probability. The decoder operates as follows: In a block of three received bits, if the number of zeros exceeds the number of ones, the decoder decides in favor of a 0, and if the number of ones exceeds the number of zeros, the decoder decides in favor of a 1. Assuming a binary symmetric channel with crossover probability $p = 0.1$, the average probability of error is _____

Q.50 An analog pulse $s(t)$ is transmitted over an additive white Gaussian noise (AWGN) channel. The received signal is $r(t) = s(t) + n(t)$, where $n(t)$ is additive white Gaussian noise with power spectral density $\frac{N_0}{2}$. The received signal is passed through a filter with impulse response $h(t)$. Let E_s and E_h denote the energies of the pulse $s(t)$ and the filter $h(t)$, respectively. When the signal-to-noise ratio (SNR) is maximized at the output of the filter (SNR_{\max}), which of the following holds?

- (A) $E_s = E_h$; $\text{SNR}_{\max} = \frac{2E_s}{N_0}$ (B) $E_s = E_h$; $\text{SNR}_{\max} = \frac{E_s}{2N_0}$
 (C) $E_s > E_h$; $\text{SNR}_{\max} > \frac{2E_s}{N_0}$ (D) $E_s < E_h$; $\text{SNR}_{\max} = \frac{2E_h}{N_0}$

Q.51 The current density in a medium is given by

$$\vec{j} = \frac{400 \sin\theta}{2\pi(r^2 + 4)} \hat{a}_r \text{ Am}^{-2}$$

The total current and the average current density flowing through the portion of a spherical surface $r = 0.8$ m, $\frac{\pi}{12} \leq \theta \leq \frac{\pi}{4}$, $0 \leq \phi \leq 2\pi$ are given, respectively, by

- (A) 15.09 A, 12.86 Am^{-2} (B) 18.73 A, 13.65 Am^{-2}
 (C) 12.86 A, 9.23 Am^{-2} (D) 10.28 A, 7.56 Am^{-2}

Q.52 An antenna pointing in a certain direction has a noise temperature of 50 K. The ambient temperature is 290 K. The antenna is connected to a pre-amplifier that has a noise figure of 2 dB and an available gain of 40 dB over an effective bandwidth of 12 MHz. The effective input noise temperature T_e for the amplifier and the noise power P_{ao} at the output of the preamplifier, respectively, are

- (A) $T_e = 169.36$ K and $P_{\text{ao}} = 3.73 \times 10^{-10}$ W (B) $T_e = 170.8$ K and $P_{\text{ao}} = 4.56 \times 10^{-10}$ W
 (C) $T_e = 182.5$ K and $P_{\text{ao}} = 3.85 \times 10^{-10}$ W (D) $T_e = 160.62$ K and $P_{\text{ao}} = 4.6 \times 10^{-10}$ W

Q.53 Two lossless X-band horn antennas are separated by a distance of 200λ . The amplitude reflection coefficients at the terminals of the transmitting and receiving antennas are 0.15 and 0.18, respectively. The maximum directivities of the transmitting and receiving antennas (over the isotropic antenna) are 18 dB and 22 dB, respectively. Assuming that the input power in the lossless transmission line connected to the antenna is 2 W, and that the antennas are perfectly aligned and polarization matched, the power (in mW) delivered to the load at the receiver is _____



- Q.54 The electric field of a uniform plane wave travelling along the negative z direction is given by the following equation:

$$\vec{E}_w^i = (\hat{a}_x + j\hat{a}_y)E_0 e^{jkz}$$

This wave is incident upon a receiving antenna placed at the origin and whose radiated electric field towards the incident wave is given by the following equation:

$$\vec{E}_a = (\hat{a}_x + 2\hat{a}_y)E_l \frac{1}{r} e^{-jkr}$$

The polarization of the incident wave, the polarization of the antenna and losses due to the polarization mismatch are, respectively,

- (A) Linear, Circular (clockwise), -5dB (B) Circular (clockwise), Linear, -5dB
 (C) Circular (clockwise), Linear, -3dB (D) Circular (anti clockwise), Linear, -3dB
- Q.55 The far-zone power density radiated by a helical antenna is approximated as:

$$\vec{W}_{rad} = \vec{W}_{average} \approx \hat{a}_r C_0 \frac{1}{r^2} \cos^4 \theta$$

The radiated power density is symmetrical with respect to ϕ and exists only in the upper hemisphere: $0 \leq \theta \leq \frac{\pi}{2}$; $0 \leq \phi \leq 2\pi$; C_0 is a constant. The power radiated by the antenna (in watts) and the maximum directivity of the antenna, respectively, are

- (A) $1.5C_0$, 10dB (B) $1.256C_0$, 10dB (C) $1.256C_0$, 12dB (D) $1.5C_0$, 12dB

END OF THE QUESTION PAPER

Q. No	Type	Section	Key	Marks
1	MCQ	GA	A	1
2	MCQ	GA	B	1
3	MCQ	GA	A	1
4	MCQ	GA	A	1
5	MCQ	GA	C	1
6	MCQ	GA	C	2
7	MCQ	GA	B	2
8	MCQ	GA	D	2
9	MCQ	GA	C	2
10	MCQ	GA	C	2
1	MCQ	EC-1	C	1
2	NAT	EC-1	0.9 : 1.1	1
3	MCQ	EC-1	B	1
4	MCQ	EC-1	A	1
5	MCQ	EC-1	C	1
6	MCQ	EC-1	C	1
7	MCQ	EC-1	B	1
8	MCQ	EC-1	B	1
9	MCQ	EC-1	D	1
10	NAT	EC-1	12 : 14	1
11	MCQ	EC-1	A	1
12	MCQ	EC-1	C	1
13	MCQ	EC-1	B	1
14	NAT	EC-1	2.9 : 3.1	1
15	MCQ	EC-1	A	1
16	MCQ	EC-1	A	1
17	MCQ	EC-1	C	1
18	MCQ	EC-1	C	1
19	MCQ	EC-1	D	1
20	MCQ	EC-1	A	1
21	NAT	EC-1	34.5 : 35.5	1
22	NAT	EC-1	4.9 : 5.1	1
23	NAT	EC-1	0.49 : 0.51	1
24	NAT	EC-1	-0.28 : -0.22	1
25	MCQ	EC-1	B	1
26	NAT	EC-1	18 : 22	2
27	NAT	EC-1	230 : 240	2
28	NAT	EC-1	-136 : -132	2
29	NAT	EC-1	4.66 : 4.76	2
30	MCQ	EC-1	MTA	2
31	MCQ	EC-1	A	2
32	MCQ	EC-1	C	2
33	NAT	EC-1	0.9 : 1.1	2
34	NAT	EC-1	0.78 : 0.82	2
35	NAT	EC-1	7.9 : 8.1	2
36	NAT	EC-1	-5.0 : -4.6	2
37	NAT	EC-1	28 : 29	2
38	NAT	EC-1	1.10 : 1.25	2
39	MCQ	EC-1	A	2



40	NAT	EC-1	14.9 : 15.5	2
41	NAT	EC-1	790 : 810 ; -810 : -790	2
42	MCQ	EC-1	MTA	2
43	MCQ	EC-1	B	2
44	MCQ	EC-1	C	2
45	NAT	EC-1	1.2 : 1.3 ; -1.3 : -1.2	2
46	NAT	EC-1	2.7 : 3.0	2
47	NAT	EC-1	3 : 3	2
48	NAT	EC-1	1.8 : 2.2	2
49	NAT	EC-1	0.025 : 0.030	2
50	MCQ	EC-1	A	2
51	MCQ	EC-1	MTA	2
52	MCQ	EC-1	A	2
53	NAT	EC-1	2.7 : 3.3	2
54	MCQ	EC-1	C ; D	2
55	MCQ	EC-1	B	2

