

**Q. 1 – Q. 5 carry one mark each.**

Q.1 Based on the given statements, select the appropriate option with respect to grammar and usage.

Statements

- (i) The height of Mr. **X** is 6 feet.  
(ii) The height of Mr. **Y** is 5 feet.

- (A) Mr. **X** is longer than Mr. **Y**.  
(B) Mr. **X** is more elongated than Mr. **Y**.  
(C) Mr. **X** is taller than Mr. **Y**.  
(D) Mr. **X** is lengthier than Mr. **Y**.

Q.2 The students \_\_\_\_\_ the teacher on teachers' day for twenty years of dedicated teaching.

- (A) facilitated (B) felicitated (C) fantasized (D) facillitated

Q.3 After India's cricket world cup victory in 1985, Shrotria who was playing both tennis and cricket till then, decided to concentrate only on cricket. And the rest is history.

What does the underlined phrase mean in this context?

- (A) history will rest in peace (B) rest is recorded in history books  
(C) rest is well known (D) rest is archaic

Q.4 Given  $(9 \text{ inches})^{\frac{1}{2}} = (0.25 \text{ yards})^{\frac{1}{2}}$ , which one of the following statements is **TRUE**?

- (A) 3 inches = 0.5 yards (B) 9 inches = 1.5 yards  
(C) 9 inches = 0.25 yards (D) 81 inches = 0.0625 yards

Q.5 **S**, **M**, **E** and **F** are working in shifts in a team to finish a project. **M** works with twice the efficiency of others but for half as many days as **E** worked. **S** and **M** have 6 hour shifts in a day, whereas **E** and **F** have 12 hours shifts. What is the ratio of contribution of **M** to contribution of **E** in the project?

- (A) 1:1 (B) 1:2 (C) 1:4 (D) 2:1



**Q. 6 – Q. 10 carry two marks each.**

Q.6 The Venn diagram shows the preference of the student population for leisure activities.

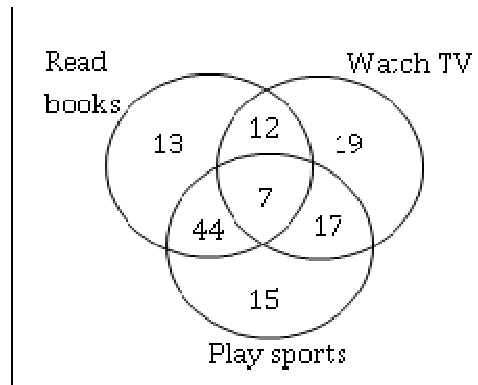

From the data given, the number of students who like to read books or play sports is \_\_\_\_\_.

- (A) 44                      (B) 51                      (C) 79                      (D) 108

Q.7 Social science disciplines were in existence in an amorphous form until the colonial period when they were institutionalized. In varying degrees, they were intended to further the colonial interest. In the time of globalization and the economic rise of postcolonial countries like India, conventional ways of knowledge production have become obsolete.

Which of the following can be logically inferred from the above statements?

- (i) Social science disciplines have become obsolete.
- (ii) Social science disciplines had a pre-colonial origin.
- (iii) Social science disciplines always promote colonialism.
- (iv) Social science must maintain disciplinary boundaries.

- (A) (ii) only                      (B) (i) and (iii) only  
 (C) (ii) and (iv) only                      (D) (iii) and (iv) only

Q.8 Two and a quarter hours back, when seen in a mirror, the reflection of a wall clock without number markings seemed to show 1:30. What is the actual current time shown by the clock?

- (A) 8:15                      (B) 11:15                      (C) 12:15                      (D) 12:45

Q.9 **M** and **N** start from the same location. **M** travels 10 km East and then 10 km North-East. **N** travels 5 km South and then 4 km South-East. What is the shortest distance (in km) between **M** and **N** at the end of their travel?

- (A) 18.60                      (B) 22.50                      (C) 20.61                      (D) 25.00



- Q.10 A wire of length 340 mm is to be cut into two parts. One of the parts is to be made into a square and the other into a rectangle where sides are in the ratio of 1:2. What is the length of the side of the square (in mm) such that the combined area of the square and the rectangle is a **MINIMUM**?
- (A) 30                      (B) 40                      (C) 120                      (D) 180

**END OF THE QUESTION PAPER**



**Q. 1 – Q. 25 carry one mark each.**

Q.1

The value of  $x$  for which the matrix  $A = \begin{bmatrix} 3 & 2 & 4 \\ 9 & 7 & 13 \\ -6 & -4 & -9 + x \end{bmatrix}$  has zero as an eigenvalue is \_\_\_\_\_

Q.2 Consider the complex valued function  $f(z) = 2z^3 + b|z|^3$  where  $z$  is a complex variable. The value of  $b$  for which the function  $f(z)$  is analytic is \_\_\_\_\_

Q.3 As  $x$  varies from  $-1$  to  $+3$ , which one of the following describes the behaviour of the function  $f(x) = x^3 - 3x^2 + 1$ ?

- (A)  $f(x)$  increases monotonically.  
 (B)  $f(x)$  increases, then decreases and increases again.  
 (C)  $f(x)$  decreases, then increases and decreases again.  
 (D)  $f(x)$  increases and then decreases.

Q.4 How many distinct values of  $x$  satisfy the equation  $\sin(x) = x/2$ , where  $x$  is in radians?

- (A) 1                      (B) 2                      (C) 3                      (D) 4 or more

Q.5 Consider the time-varying vector  $\mathbf{I} = \hat{x} 15 \cos(\omega t) + \hat{y} 5 \sin(\omega t)$  in Cartesian coordinates, where  $\omega > 0$  is a constant. When the vector magnitude  $|\mathbf{I}|$  is at its minimum value, the angle  $\theta$  that  $\mathbf{I}$  makes with the  $x$  axis (in degrees, such that  $0 \leq \theta \leq 180$ ) is \_\_\_\_\_

Q.6 In the circuit shown below,  $V_S$  is a constant voltage source and  $I_L$  is a constant current load.

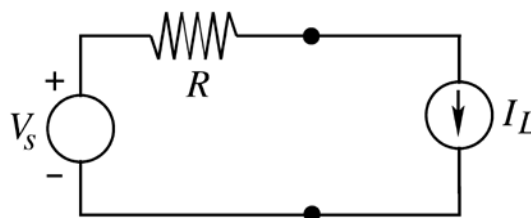

The value of  $I_L$  that maximizes the power absorbed by the constant current load is

- (A)  $\frac{V_S}{4R}$                       (B)  $\frac{V_S}{2R}$                       (C)  $\frac{V_S}{R}$                       (D)  $\infty$

Q.7 The switch has been in position 1 for a long time and abruptly changes to position 2 at  $t = 0$ .

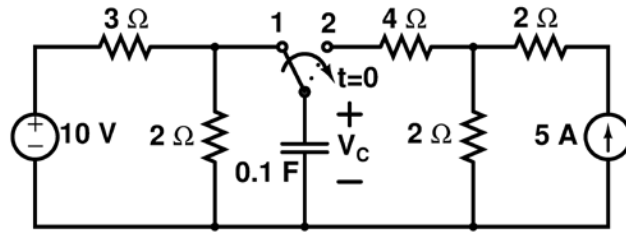

If time  $t$  is in seconds, the capacitor voltage  $V_C$  (in volts) for  $t > 0$  is given by

- (A)  $4(1 - \exp(-t/0.5))$
- (B)  $10 - 6 \exp(-t/0.5)$
- (C)  $4(1 - \exp(-t/0.6))$
- (D)  $10 - 6 \exp(-t/0.6)$

Q.8 The figure shows an RLC circuit with a sinusoidal current source.

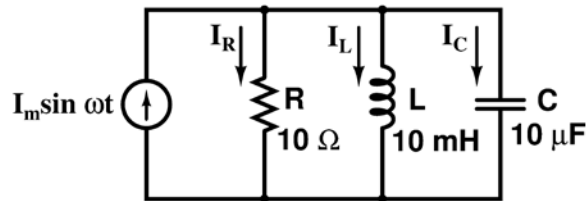

At resonance, the ratio  $|I_L|/|I_R|$ , i.e., the ratio of the magnitudes of the inductor current phasor and the resistor current phasor, is \_\_\_\_\_

Q.9 The z-parameter matrix for the two-port network shown is

$$\begin{bmatrix} 2j\omega & j\omega \\ j\omega & 3 + 2j\omega \end{bmatrix}$$

where the entries are in  $\Omega$ . Suppose  $Z_b(j\omega) = R_b + j\omega$ .

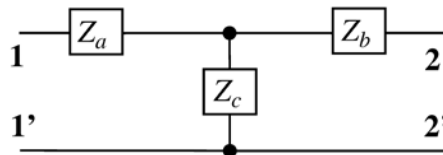

Then the value of  $R_b$  (in  $\Omega$ ) equals \_\_\_\_\_

Q.10 The energy of the signal  $x(t) = \frac{\sin(4\pi t)}{4\pi t}$  is \_\_\_\_\_



Q.11 The Ebers-Moll model of a BJT is valid

- (A) only in active mode
- (B) only in active and saturation modes
- (C) only in active and cut-off modes
- (D) in active, saturation and cut-off modes

Q.12 A long-channel NMOS transistor is biased in the linear region with  $V_{DS}=50\text{ mV}$  and is used as a resistance. Which one of the following statements is NOT correct?

- (A) If the device width  $W$  is increased, the resistance decreases.
- (B) If the threshold voltage is reduced, the resistance decreases.
- (C) If the device length  $L$  is increased, the resistance increases.
- (D) If  $V_{GS}$  is increased, the resistance increases.

Q.13 Assume that the diode in the figure has  $V_{on} = 0.7\text{ V}$ , but is otherwise ideal.

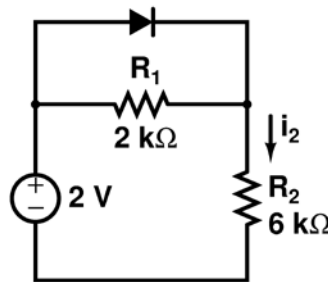

The magnitude of the current  $i_2$  (in mA) is equal to \_\_\_\_\_

Q.14 Resistor  $R_1$  in the circuit below has been adjusted so that  $I_1 = 1\text{ mA}$ . The bipolar transistors Q1 and Q2 are perfectly matched and have very high current gain, so their base currents are negligible. The supply voltage  $V_{cc}$  is 6 V. The thermal voltage  $kT/q$  is 26 mV.

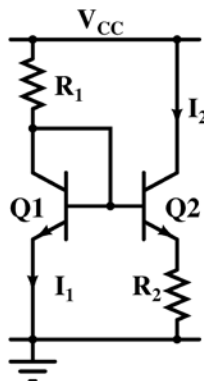

The value of  $R_2$  (in  $\Omega$ ) for which  $I_2=100\ \mu\text{A}$  is \_\_\_\_\_

Q.15 Which one of the following statements is correct about an ac-coupled common-emitter amplifier operating in the mid-band region?

- (A) The device parasitic capacitances behave like open circuits, whereas coupling and bypass capacitances behave like short circuits.
- (B) The device parasitic capacitances, coupling capacitances and bypass capacitances behave like open circuits.
- (C) The device parasitic capacitances, coupling capacitances and bypass capacitances behave like short circuits.
- (D) The device parasitic capacitances behave like short circuits, whereas coupling and bypass capacitances behave like open circuits.

Q.16 Transistor geometries in a CMOS inverter have been adjusted to meet the requirement for worst case charge and discharge times for driving a load capacitor  $C$ . This design is to be converted to that of a NOR circuit in the same technology, so that its worst case charge and discharge times while driving the same capacitor are similar. The channel lengths of all transistors are to be kept unchanged. Which one of the following statements is correct?

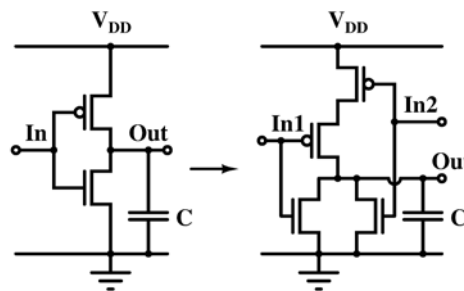

- (A) Widths of PMOS transistors should be doubled, while widths of NMOS transistors should be halved.
- (B) Widths of PMOS transistors should be doubled, while widths of NMOS transistors should not be changed.
- (C) Widths of PMOS transistors should be halved, while widths of NMOS transistors should not be changed.
- (D) Widths of PMOS transistors should be unchanged, while widths of NMOS transistors should be halved.

Q.17 Assume that all the digital gates in the circuit shown in the figure are ideal, the resistor  $R = 10\text{ k}\Omega$  and the supply voltage is  $5\text{ V}$ . The D flip-flops  $D_1, D_2, D_3, D_4$  and  $D_5$  are initialized with logic values  $0, 1, 0, 1$  and  $0$ , respectively. The clock has a 30% duty cycle.

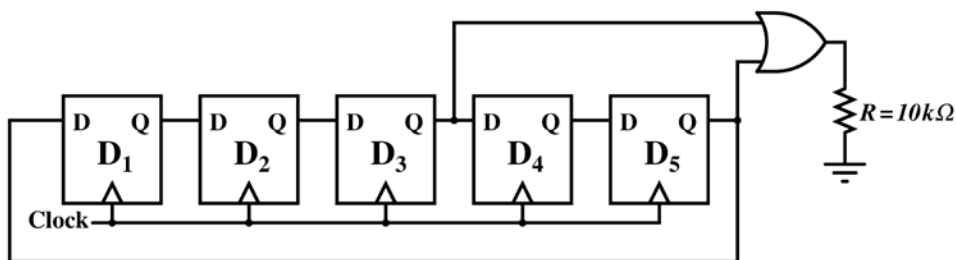

The average power dissipated (in mW) in the resistor  $R$  is \_\_\_\_\_

- Q.18 A 4:1 multiplexer is to be used for generating the output carry of a full adder. A and B are the bits to be added while  $C_{in}$  is the input carry and  $C_{out}$  is the output carry. A and B are to be used as the select bits with A being the more significant select bit.

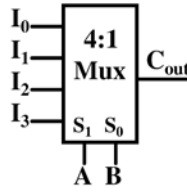

Which one of the following statements correctly describes the choice of signals to be connected to the inputs  $I_0$ ,  $I_1$ ,  $I_2$  and  $I_3$  so that the output is  $C_{out}$ ?

- (A)  $I_0=0$ ,  $I_1=C_{in}$ ,  $I_2=C_{in}$  and  $I_3=1$   
 (B)  $I_0=1$ ,  $I_1=C_{in}$ ,  $I_2=C_{in}$  and  $I_3=1$   
 (C)  $I_0=C_{in}$ ,  $I_1=0$ ,  $I_2=1$  and  $I_3=C_{in}$   
 (D)  $I_0=0$ ,  $I_1=C_{in}$ ,  $I_2=1$  and  $I_3=C_{in}$
- Q.19 The response of the system  $G(s) = \frac{s-2}{(s+1)(s+3)}$  to the unit step input  $u(t)$  is  $y(t)$ . The value of  $\frac{dy}{dt}$  at  $t = 0^+$  is \_\_\_\_\_
- Q.20 The number and direction of encirclements around the point  $-1 + j0$  in the complex plane by the Nyquist plot of  $G(s) = \frac{1-s}{4+2s}$  is
- (A) zero. (B) one, anti-clockwise.  
 (C) one, clockwise. (D) two, clockwise.
- Q.21 A discrete memoryless source has an alphabet  $\{a_1, a_2, a_3, a_4\}$  with corresponding probabilities  $\left\{\frac{1}{2}, \frac{1}{4}, \frac{1}{8}, \frac{1}{8}\right\}$ . The minimum required average codeword length in bits to represent this source for error-free reconstruction is \_\_\_\_\_
- Q.22 A speech signal is sampled at 8 kHz and encoded into PCM format using 8 bits/sample. The PCM data is transmitted through a baseband channel via 4-level PAM. The minimum bandwidth (in kHz) required for transmission is \_\_\_\_\_
- Q.23 A uniform and constant magnetic field  $\mathbf{B} = \hat{\mathbf{z}}B$  exists in the  $\hat{\mathbf{z}}$  direction in vacuum. A particle of mass  $m$  with a small charge  $q$  is introduced into this region with an initial velocity  $\mathbf{v} = \hat{\mathbf{x}}v_x + \hat{\mathbf{z}}v_z$ . Given that  $B$ ,  $m$ ,  $q$ ,  $v_x$  and  $v_z$  are all non-zero, which one of the following describes the eventual trajectory of the particle?
- (A) Helical motion in the  $\hat{\mathbf{z}}$  direction.  
 (B) Circular motion in the  $xy$  plane.  
 (C) Linear motion in the  $\hat{\mathbf{z}}$  direction.  
 (D) Linear motion in the  $\hat{\mathbf{x}}$  direction.



- Q.24 Let the electric field vector of a plane electromagnetic wave propagating in a homogenous medium be expressed as  $\mathbf{E} = \hat{\mathbf{x}}E_x e^{-j(\omega t - \beta z)}$ , where the propagation constant  $\beta$  is a function of the angular frequency  $\omega$ . Assume that  $\beta(\omega)$  and  $E_x$  are known and are real. From the information available, which one of the following CANNOT be determined?
- (A) The type of polarization of the wave.
  - (B) The group velocity of the wave.
  - (C) The phase velocity of the wave.
  - (D) The power flux through the  $z = 0$  plane.
- Q.25 Light from free space is incident at an angle  $\theta_i$  to the normal of the facet of a step-index large core optical fibre. The core and cladding refractive indices are  $n_1 = 1.5$  and  $n_2 = 1.4$ , respectively.

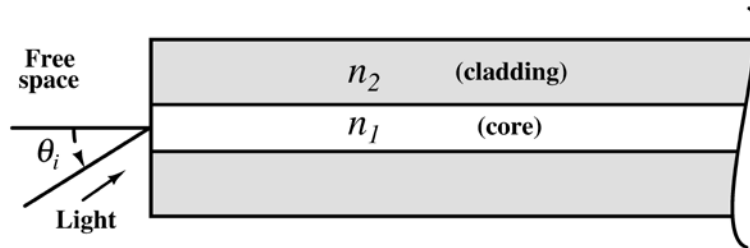

The maximum value of  $\theta_i$  (in degrees) for which the incident light will be guided in the core of the fibre is \_\_\_\_\_

**Q. 26 – Q. 55 carry two marks each.**

- Q.26 The ordinary differential equation  $\frac{dx}{dt} = -3x + 2$ , with  $x(0) = 1$  is to be solved using the forward Euler method. The largest time step that can be used to solve the equation without making the numerical solution unstable is \_\_\_\_\_
- Q.27 Suppose C is the closed curve defined as the circle  $x^2 + y^2 = 1$  with C oriented anti-clockwise. The value of  $\oint_C (xy^2 dx + x^2 y dy)$  over the curve C equals \_\_\_\_\_
- Q.28 Two random variables X and Y are distributed according to

$$f_{X,Y}(x, y) = \begin{cases} (x + y), & 0 \leq x \leq 1, \quad 0 \leq y \leq 1 \\ 0, & \text{otherwise.} \end{cases}$$

The probability  $P(X + Y \leq 1)$  is \_\_\_\_\_

Q.29

The matrix  $A = \begin{bmatrix} a & 0 & 3 & 7 \\ 2 & 5 & 1 & 3 \\ 0 & 0 & 2 & 4 \\ 0 & 0 & 0 & b \end{bmatrix}$  has  $\det(A) = 100$  and  $\text{trace}(A) = 14$ .

The value of  $|a - b|$  is \_\_\_\_\_

Q.30 In the given circuit, each resistor has a value equal to  $1 \Omega$ .

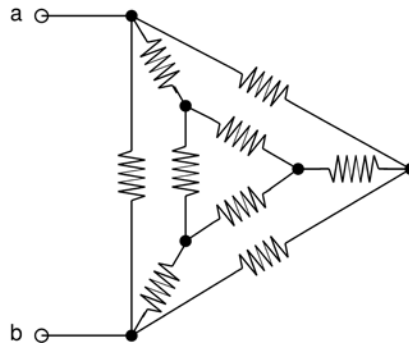

What is the equivalent resistance across the terminals  $a$  and  $b$ ?

- (A)  $1/6 \Omega$                       (B)  $1/3 \Omega$                       (C)  $9/20 \Omega$                       (D)  $8/15 \Omega$

Q.31 In the circuit shown in the figure, the magnitude of the current (in amperes) through  $R_2$  is \_\_\_\_

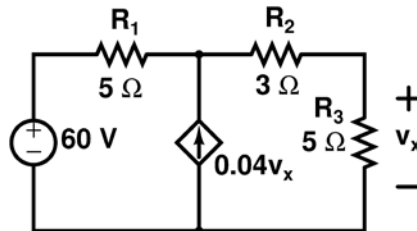

Q.32 A continuous-time filter with transfer function  $H(s) = \frac{2s + 6}{s^2 + 6s + 8}$  is converted to a discrete-time filter with transfer function  $G(z) = \frac{2z^2 - 0.5032z}{z^2 - 0.5032z + k}$  so that the impulse response of the continuous-time filter, sampled at 2 Hz, is identical at the sampling instants to the impulse response of the discrete time filter. The value of  $k$  is \_\_\_\_\_

Q.33 The Discrete Fourier Transform (DFT) of the 4-point sequence

$$x[n] = \{x[0], x[1], x[2], x[3]\} = \{3, 2, 3, 4\}$$

$$X[k] = \{X[0], X[1], X[2], X[3]\} = \{12, 2j, 0, -2j\}.$$

If  $X_1[k]$  is the DFT of the 12-point sequence  $x_1[n] = \{3, 0, 0, 2, 0, 0, 3, 0, 0, 4, 0, 0\}$ ,

the value of  $\left| \frac{X_1[8]}{X_1[11]} \right|$  is \_\_\_\_\_

Q.34 The switch S in the circuit shown has been closed for a long time. It is opened at time  $t = 0$  and remains open after that. Assume that the diode has zero reverse current and zero forward voltage drop.

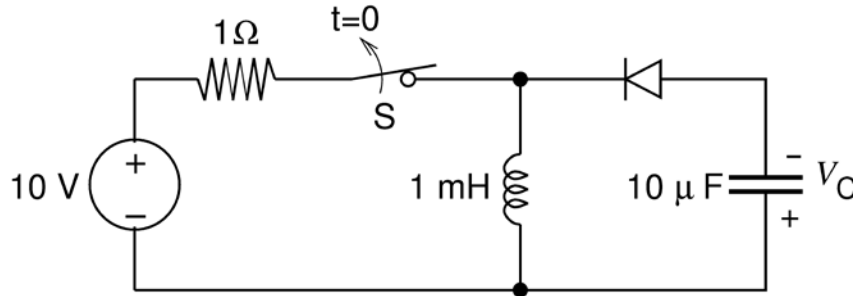

The steady state magnitude of the capacitor voltage  $V_C$  (in volts) is \_\_\_\_\_

Q.35 A voltage  $V_G$  is applied across a MOS capacitor with metal gate and p-type silicon substrate at  $T=300$  K. The inversion carrier density (in number of carriers per unit area) for  $V_G = 0.8$  V is  $2 \times 10^{11} \text{ cm}^{-2}$ . For  $V_G = 1.3$  V, the inversion carrier density is  $4 \times 10^{11} \text{ cm}^{-2}$ . What is the value of the inversion carrier density for  $V_G = 1.8$  V?

- (A)  $4.5 \times 10^{11} \text{ cm}^{-2}$
- (B)  $6.0 \times 10^{11} \text{ cm}^{-2}$
- (C)  $7.2 \times 10^{11} \text{ cm}^{-2}$
- (D)  $8.4 \times 10^{11} \text{ cm}^{-2}$

Q.36 Consider avalanche breakdown in a silicon  $p^+n$  junction. The  $n$ -region is uniformly doped with a donor density  $N_D$ . Assume that breakdown occurs when the magnitude of the electric field at any point in the device becomes equal to the critical field  $E_{crit}$ . Assume  $E_{crit}$  to be independent of  $N_D$ . If the built-in voltage of the  $p^+n$  junction is much smaller than the breakdown voltage,  $V_{BR}$ , the relationship between  $V_{BR}$  and  $N_D$  is given by

- (A)  $V_{BR} \times \sqrt{N_D} = \text{constant}$
- (B)  $N_D \times \sqrt{V_{BR}} = \text{constant}$
- (C)  $N_D \times V_{BR} = \text{constant}$
- (D)  $N_D / V_{BR} = \text{constant}$

Q.37 Consider a region of silicon devoid of electrons and holes, with an ionized donor density of  $N_d^+ = 10^{17} \text{ cm}^{-3}$ . The electric field at  $x = 0$  is 0 V/cm and the electric field at  $x = L$  is 50 kV/cm in the positive  $x$  direction. Assume that the electric field is zero in the  $y$  and  $z$  directions at all points.

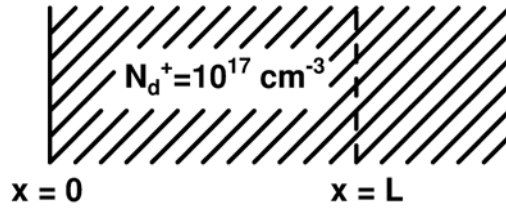

Given  $q = 1.6 \times 10^{-19}$  coulomb,  $\epsilon_0 = 8.85 \times 10^{-14}$  F/cm,  $\epsilon_r = 11.7$  for silicon, the value of  $L$  in nm is \_\_\_\_\_

Q.38 Consider a long-channel NMOS transistor with source and body connected together. Assume that the electron mobility is independent of  $V_{GS}$  and  $V_{DS}$ . Given,

$g_m = 0.5 \mu\text{A/V}$  for  $V_{DS} = 50 \text{ mV}$  and  $V_{GS} = 2 \text{ V}$ ,  
 $g_d = 8 \mu\text{A/V}$  for  $V_{GS} = 2 \text{ V}$  and  $V_{DS} = 0 \text{ V}$ ,

where  $g_m = \frac{\partial I_D}{\partial V_{GS}}$  and  $g_d = \frac{\partial I_D}{\partial V_{DS}}$

The threshold voltage (in volts) of the transistor is \_\_\_\_\_

Q.39 The figure shows a half-wave rectifier with a  $475 \mu\text{F}$  filter capacitor. The load draws a constant current  $I_O = 1 \text{ A}$  from the rectifier. The figure also shows the input voltage  $V_i$ , the output voltage  $V_C$  and the peak-to-peak voltage ripple  $u$  on  $V_C$ . The input voltage  $V_i$  is a triangle-wave with an amplitude of 10 V and a period of 1 ms.

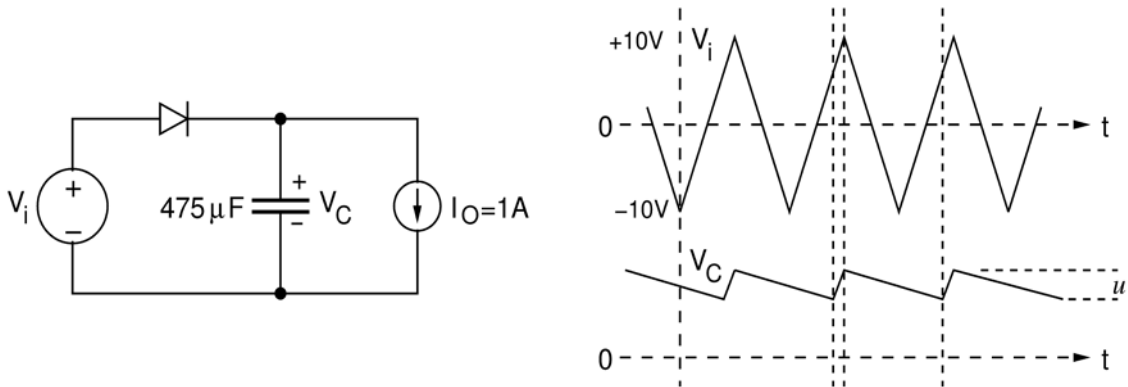

The value of the ripple  $u$  (in volts) is \_\_\_\_\_

Q.40 In the opamp circuit shown, the Zener diodes Z1 and Z2 clamp the output voltage  $V_O$  to +5 V or -5 V. The switch S is initially closed and is opened at time  $t = 0$ .

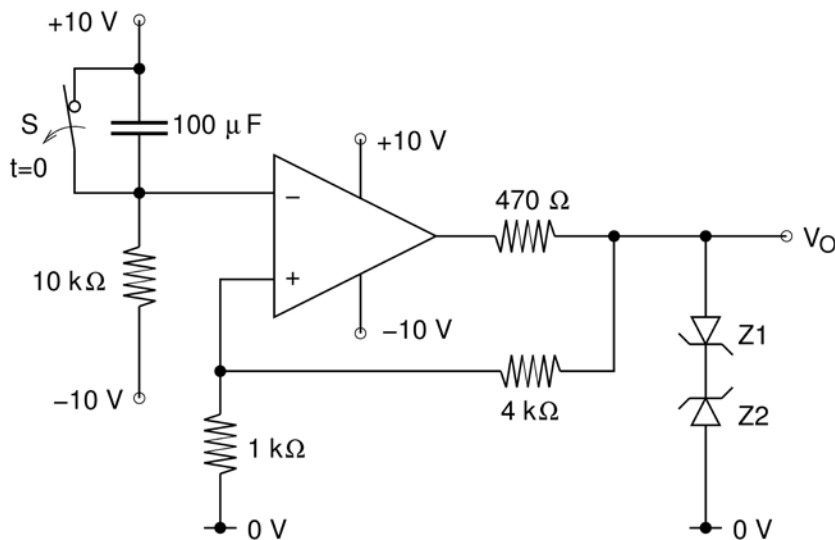

The time  $t = t_1$  (in seconds) at which  $V_O$  changes state is \_\_\_\_\_

Q.41 An opamp has a finite open loop voltage gain of 100. Its input offset voltage  $V_{ios}$  ( $= +5\text{mV}$ ) is modeled as shown in the circuit below. The amplifier is ideal in all other respects.  $V_{input}$  is 25 mV.

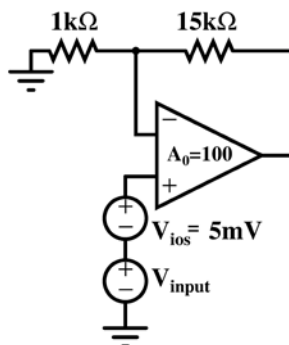

The output voltage (in millivolts) is \_\_\_\_\_

Q.42 An 8 Kbyte ROM with an active low Chip Select input ( $\overline{CS}$ ) is to be used in an 8085 microprocessor based system. The ROM should occupy the address range 1000H to 2FFFH. The address lines are designated as  $A_{15}$  to  $A_0$ , where  $A_{15}$  is the most significant address bit. Which one of the following logic expressions will generate the correct  $\overline{CS}$  signal for this ROM?

- (A)  $A_{15} + A_{14} + (A_{13} \cdot A_{12} + \overline{A_{13}} \cdot \overline{A_{12}})$
- (B)  $\overline{A_{15}} \cdot \overline{A_{14}} \cdot (A_{13} + A_{12})$
- (C)  $\overline{A_{15}} \cdot \overline{A_{14}} \cdot (A_{13} \cdot \overline{A_{12}} + \overline{A_{13}} \cdot A_{12})$
- (D)  $\overline{A_{15}} + \overline{A_{14}} + A_{13} \cdot A_{12}$

Q.43 In an N bit flash ADC, the analog voltage is fed simultaneously to  $2^N - 1$  comparators. The output of the comparators is then encoded to a binary format using digital circuits. Assume that the analog voltage source  $V_{in}$  (whose output is being converted to digital format) has a source resistance of  $75 \Omega$  as shown in the circuit diagram below and the input capacitance of each comparator is  $8 \text{ pF}$ . The input must settle to an accuracy of  $1/2 \text{ LSB}$  even for a full scale input change for proper conversion. Assume that the time taken by the thermometer to binary encoder is negligible.

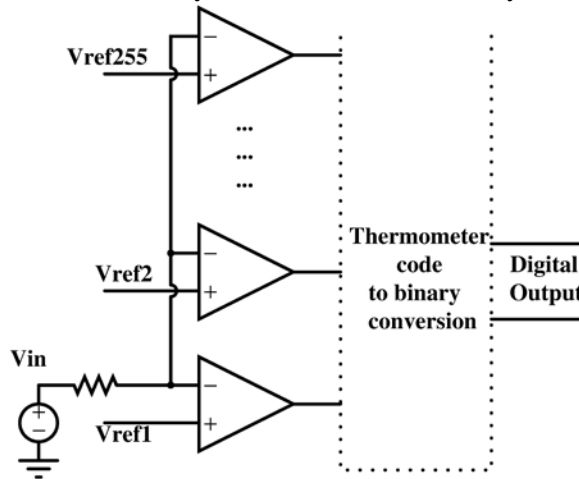

If the flash ADC has 8 bit resolution, which one of the following alternatives is closest to the maximum sampling rate ?

- (A) 1 megasamples per second
- (B) 6 megasamples per second
- (C) 64 megasamples per second
- (D) 256 megasamples per second

Q.44 The state transition diagram for a finite state machine with states A, B and C, and binary inputs X, Y and Z, is shown in the figure.

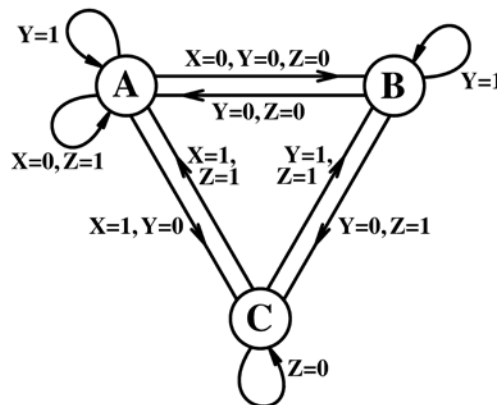

Which one of the following statements is correct?

- (A) Transitions from State A are ambiguously defined.
- (B) Transitions from State B are ambiguously defined.
- (C) Transitions from State C are ambiguously defined.
- (D) All of the state transitions are defined unambiguously.

Q.45 In the feedback system shown below  $G(s) = \frac{1}{(s^2+2s)}$ .

The step response of the closed-loop system should have minimum settling time and have no overshoot.

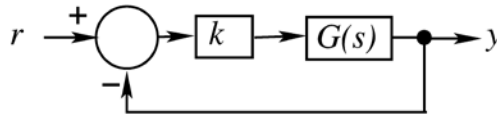

The required value of gain  $k$  to achieve this is \_\_\_\_\_

Q.46 In the feedback system shown below  $G(s) = \frac{1}{(s+1)(s+2)(s+3)}$ .

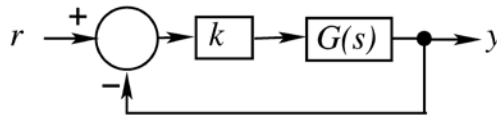

The positive value of  $k$  for which the gain margin of the loop is exactly 0 dB and the phase margin of the loop is exactly zero degree is \_\_\_\_\_

Q.47 The asymptotic Bode phase plot of  $G(s) = \frac{k}{(s+0.1)(s+10)(s+p_1)}$ , with  $k$  and  $p_1$  both positive, is shown below.

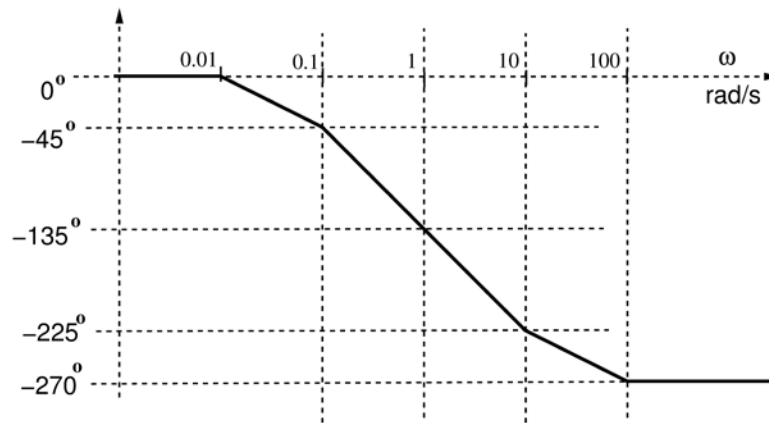

The value of  $p_1$  is \_\_\_\_\_

Q.48 An information source generates a binary sequence  $\{\alpha_n\}$ .  $\alpha_n$  can take one of the two possible values  $-1$  and  $+1$  with equal probability and are statistically independent and identically distributed. This sequence is precoded to obtain another sequence  $\{\beta_n\}$ , as  $\beta_n = \alpha_n + k \alpha_{n-3}$ . The sequence  $\{\beta_n\}$  is used to modulate a pulse  $g(t)$  to generate the baseband signal

$$X(t) = \sum_{n=-\infty}^{\infty} \beta_n g(t - nT), \text{ where } g(t) = \begin{cases} 1, & 0 \leq t \leq T \\ 0, & \text{otherwise.} \end{cases}$$

If there is a null at  $f = \frac{1}{3T}$  in the power spectral density of  $X(t)$ , then  $k$  is \_\_\_\_\_

Q.49 An ideal band-pass channel 500 Hz - 2000 Hz is deployed for communication. A modem is designed to transmit bits at the rate of 4800 bits/s using 16-QAM. The roll-off factor of a pulse with a raised cosine spectrum that utilizes the entire frequency band is \_\_\_\_\_

Q.50 Consider a random process  $X(t) = 3V(t) - 8$ , where  $V(t)$  is a zero mean stationary random process with autocorrelation  $R_v(\tau) = 4e^{-5|\tau|}$ . The power in  $X(t)$  is \_\_\_\_\_

Q.51 A binary communication system makes use of the symbols “zero” and “one”. There are channel errors. Consider the following events:

$x_0$  : a "zero" is transmitted

$x_1$  : a "one" is transmitted

$y_0$  : a "zero" is received

$y_1$  : a "one" is received

The following probabilities are given:  $P(x_0) = \frac{1}{2}$ ,  $P(y_0|x_0) = \frac{3}{4}$ , and  $P(y_0|x_1) = \frac{1}{2}$ . The information in bits that you obtain when you learn which symbol has been received (while you know that a “zero” has been transmitted) is \_\_\_\_\_

Q.52 The parallel-plate capacitor shown in the figure has movable plates. The capacitor is charged so that the energy stored in it is  $E$  when the plate separation is  $d$ . The capacitor is then isolated electrically and the plates are moved such that the plate separation becomes  $2d$ .

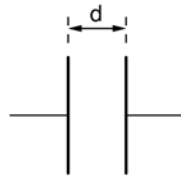

At this new plate separation, what is the energy stored in the capacitor, neglecting fringing effects?

(A)  $2E$

(B)  $\sqrt{2}E$

(C)  $E$

(D)  $E/2$

Q.53 A lossless microstrip transmission line consists of a trace of width  $w$ . It is drawn over a practically infinite ground plane and is separated by a dielectric slab of thickness  $t$  and relative permittivity  $\epsilon_r > 1$ . The inductance per unit length and the characteristic impedance of this line are  $L$  and  $Z_0$ , respectively.

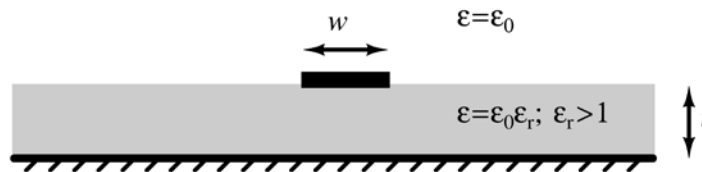

Which one of the following inequalities is always satisfied?

(A)  $Z_0 > \sqrt{\frac{Lt}{\epsilon_0 \epsilon_r w}}$

(B)  $Z_0 < \sqrt{\frac{Lt}{\epsilon_0 \epsilon_r w}}$

(C)  $Z_0 > \sqrt{\frac{Lw}{\epsilon_0 \epsilon_r t}}$

(D)  $Z_0 < \sqrt{\frac{Lw}{\epsilon_0 \epsilon_r t}}$



Q.54 A microwave circuit consisting of lossless transmission lines  $T_1$  and  $T_2$  is shown in the figure. The plot shows the magnitude of the input reflection coefficient  $\Gamma$  as a function of frequency  $f$ . The phase velocity of the signal in the transmission lines is  $2 \times 10^8$  m/s.

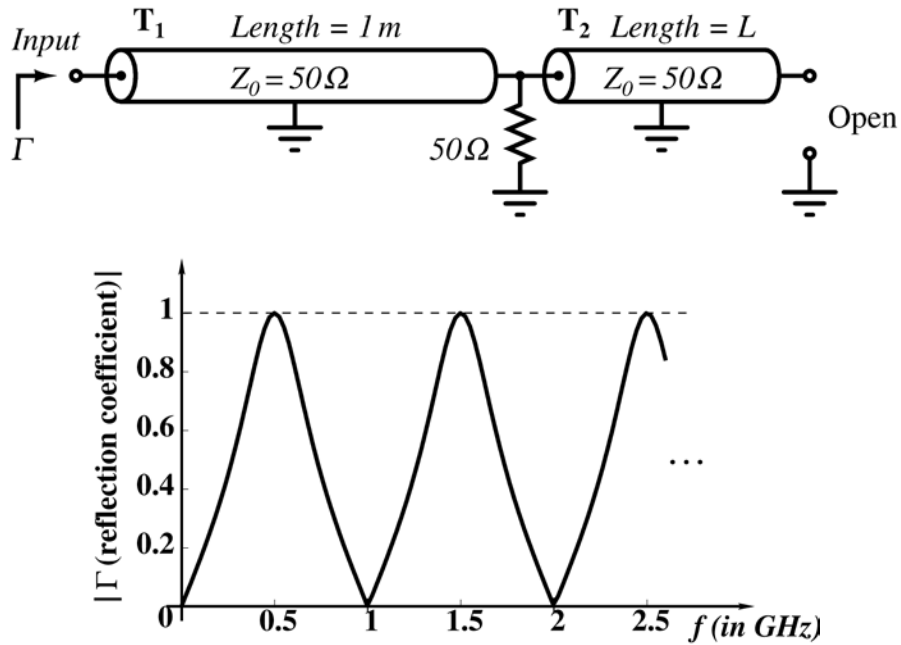

The length  $L$  (in meters) of  $T_2$  is \_\_\_\_\_

Q.55 A positive charge  $q$  is placed at  $x = 0$  between two infinite metal plates placed at  $x = -d$  and at  $x = +d$  respectively. The metal plates lie in the  $yz$  plane.

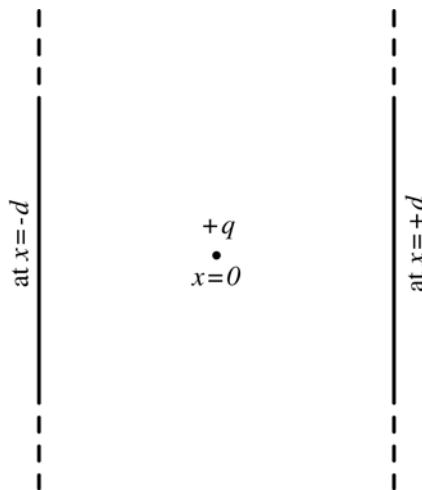

The charge is at rest at  $t = 0$ , when a voltage  $+V$  is applied to the plate at  $-d$  and voltage  $-V$  is applied to the plate at  $x = +d$ . Assume that the quantity of the charge  $q$  is small enough that it does not perturb the field set up by the metal plates. The time that the charge  $q$  takes to reach the right plate is proportional to

- (A)  $d / V$
- (B)  $\sqrt{d} / V$
- (C)  $d / \sqrt{V}$
- (D)  $\sqrt{d/V}$

**END OF THE QUESTION PAPER**



Q. No	Type	Section	Key	Marks
1	MCQ	GA	C	1
2	MCQ	GA	B	1
3	MCQ	GA	C	1
4	MCQ	GA	C	1
5	MCQ	GA	B	1
6	MCQ	GA	D	2
7	MCQ	GA	A	2
8	MCQ	GA	D	2
9	MCQ	GA	C	2
10	MCQ	GA	B	2
1	NAT	EC-2	0.95 : 1.05	1
2	NAT	EC-2	0.0 : 0.0	1
3	MCQ	EC-2	B	1
4	MCQ	EC-2	C	1
5	NAT	EC-2	90 : 90	1
6	MCQ	EC-2	B	1
7	MCQ	EC-2	D	1
8	NAT	EC-2	0.30 : 0.34	1
9	NAT	EC-2	2.98 : 3.02	1
10	NAT	EC-2	0.24 : 0.26	1
11	MCQ	EC-2	D	1
12	MCQ	EC-2	D	1
13	NAT	EC-2	0.25 : 0.25	1
14	NAT	EC-2	570 : 610	1
15	MCQ	EC-2	A	1
16	MCQ	EC-2	B	1
17	NAT	EC-2	1.45 : 1.55	1
18	MCQ	EC-2	A	1
19	NAT	EC-2	0.96 : 1.04	1
20	MCQ	EC-2	A	1
21	NAT	EC-2	1.74 : 1.76	1
22	NAT	EC-2	15.9 : 16.1	1
23	MCQ	EC-2	A	1
24	MCQ	EC-2	D	1
25	NAT	EC-2	32:33	1
26	NAT	EC-2	0.6 : 0.7	2
27	NAT	EC-2	-0.03 : 0.03	2
28	NAT	EC-2	0.32 : 0.34	2
29	NAT	EC-2	2.9 : 3.1	2
30	MCQ	EC-2	D	2
31	NAT	EC-2	4.9 : 5.1	2
32	NAT	EC-2	0.04 : 0.06	2
33	NAT	EC-2	5.9 : 6.1	2
34	NAT	EC-2	99 : 101	2
35	MCQ	EC-2	B	2
36	MCQ	EC-2	C	2
37	NAT	EC-2	30:34	2
38	NAT	EC-2	1.18 : 1.22	2
39	NAT	EC-2	1.9 : 2.2	2



40	NAT	EC-2	0.7 : 0.9	2
41	NAT	EC-2	400 : 425	2
42	MCQ	EC-2	A	2
43	MCQ	EC-2	A	2
44	MCQ	EC-2	C	2
45	NAT	EC-2	0.95 : 1.05	2
46	NAT	EC-2	59.5 : 60.5	2
47	NAT	EC-2	0.95 : 1.05	2
48	NAT	EC-2	-1.01 : -0.99	2
49	NAT	EC-2	0.24 : 0.26	2
50	NAT	EC-2	99 : 101	2
51	NAT	EC-2	0.80 : 0.82	2
52	MCQ	EC-2	A	2
53	MCQ	EC-2	B	2
54	NAT	EC-2	0.09 : 0.11	2
55	MCQ	EC-2	C	2

