

Q. 1 – Q. 5 carry one mark each.

Q.1 An apple costs Rs. 10. An onion costs Rs. 8.

Select the most suitable sentence with respect to grammar and usage.

- (A) The price of an apple is greater than an onion.
- (B) The price of an apple is more than onion.
- (C) The price of an apple is greater than that of an onion.
- (D) Apples are more costlier than onions.

Q.2 The Buddha said, “Holding on to anger is like grasping a hot coal with the intent of throwing it at someone else; you are the one who gets burnt.”

Select the word below which is closest in meaning to the word underlined above.

- (A) burning
- (B) igniting
- (C) clutching
- (D) flinging

Q.3 **M** has a son **Q** and a daughter **R**. He has no other children. **E** is the mother of **P** and daughter-in-law of **M**. How is **P** related to **M**?

- (A) **P** is the son-in-law of **M**.
- (B) **P** is the grandchild of **M**.
- (C) **P** is the daughter-in law of **M**.
- (D) **P** is the grandfather of **M**.

Q.4 The number that least fits this set: (324, 441, 97 and 64) is _____.

- (A) 324
- (B) 441
- (C) 97
- (D) 64

Q.5 It takes 10 s and 15 s, respectively, for two trains travelling at different constant speeds to completely pass a telegraph post. The length of the first train is 120 m and that of the second train is 150 m. The magnitude of the difference in the speeds of the two trains (in m/s) is _____.

- (A) 2.0
- (B) 10.0
- (C) 12.0
- (D) 22.0



Q. 6 – Q. 10 carry two marks each.

- Q.6 The velocity V of a vehicle along a straight line is measured in m/s and plotted as shown with respect to time in seconds. At the end of the 7 seconds, how much will the odometer reading increase by (in m)?

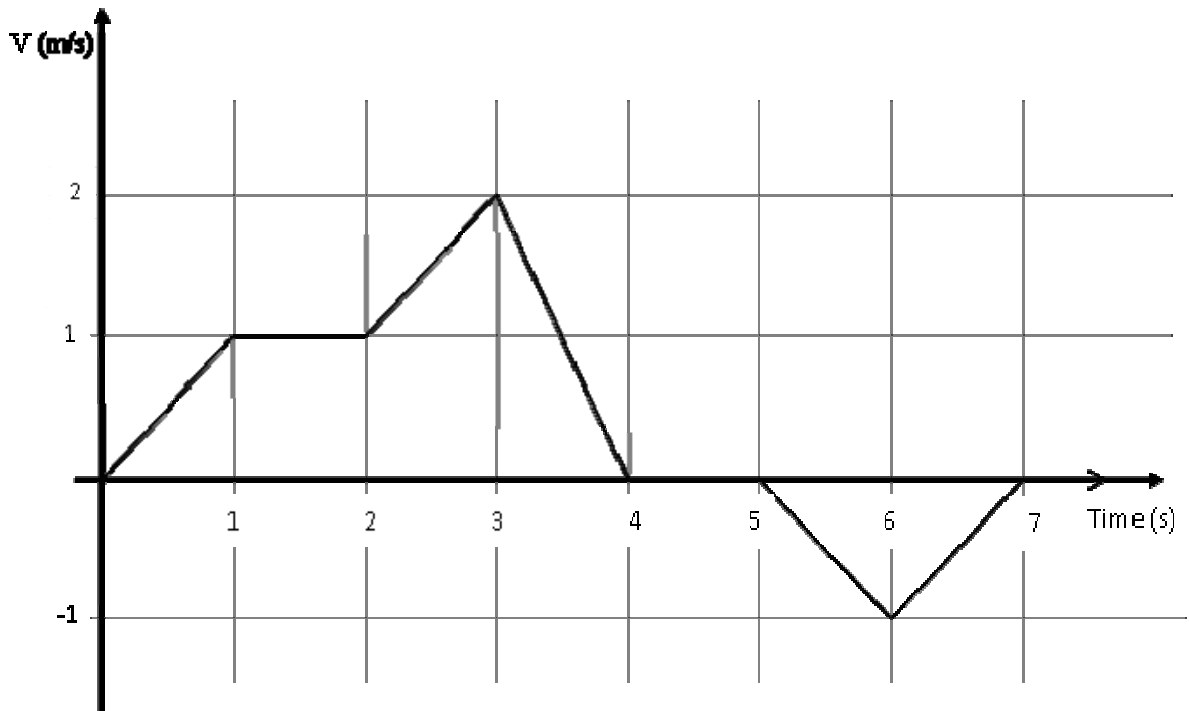

- (A) 0 (B) 3 (C) 4 (D) 5

- Q.7 The overwhelming number of people infected with rabies in India has been flagged by the World Health Organization as a source of concern. It is estimated that inoculating 70% of pets and stray dogs against rabies can lead to a significant reduction in the number of people infected with rabies.

Which of the following can be logically inferred from the above sentences?

- (A) The number of people in India infected with rabies is high.
 (B) The number of people in other parts of the world who are infected with rabies is low.
 (C) Rabies can be eradicated in India by vaccinating 70% of stray dogs.
 (D) Stray dogs are the main source of rabies worldwide.

- Q.8 A flat is shared by four first year undergraduate students. They agreed to allow the oldest of them to enjoy some extra space in the flat. Manu is two months older than Sravan, who is three months younger than Trideep. Pavan is one month older than Sravan. Who should occupy the extra space in the flat?

- (A) Manu (B) Sravan (C) Trideep (D) Pavan

- Q.9 Find the area bounded by the lines $3x+2y=14$, $2x-3y=5$ in the first quadrant.

- (A) 14.95 (B) 15.25 (C) 15.70 (D) 20.35



- Q.10 A straight line is fit to a data set $(\ln x, y)$. This line intercepts the abscissa at $\ln x = 0.1$ and has a slope of -0.02 . What is the value of y at $x = 5$ from the fit?
- (A) -0.030 (B) -0.014 (C) 0.014 (D) 0.030

END OF THE QUESTION PAPER



Q. 1 – Q. 25 carry one mark each.

Q.1 Consider a 2×2 square matrix

$$\mathbf{A} = \begin{bmatrix} \sigma & x \\ \omega & \sigma \end{bmatrix},$$

where x is unknown. If the eigenvalues of the matrix \mathbf{A} are $(\sigma + j\omega)$ and $(\sigma - j\omega)$, then x is equal to

- (A) $+j\omega$ (B) $-j\omega$ (C) $+\omega$ (D) $-\omega$

Q.2 For $f(z) = \frac{\sin(z)}{z^2}$, the residue of the pole at $z = 0$ is _____

Q.3 The probability of getting a “head” in a single toss of a biased coin is 0.3. The coin is tossed repeatedly till a “head” is obtained. If the tosses are independent, then the probability of getting “head” for the first time in the fifth toss is _____

Q.4 The integral $\int_0^1 \frac{dx}{\sqrt{1-x}}$ is equal to _____

Q.5 Consider the first order initial value problem

$$y' = y + 2x - x^2, \quad y(0) = 1, \quad (0 \leq x < \infty)$$

with exact solution $y(x) = x^2 + e^x$. For $x = 0.1$, the percentage difference between the exact solution and the solution obtained using a single iteration of the second-order Runge-Kutta method with step-size $h = 0.1$ is _____

Q.6 Consider the signal $x(t) = \cos(6\pi t) + \sin(8\pi t)$, where t is in seconds. The Nyquist sampling rate (in samples/second) for the signal $y(t) = x(2t + 5)$ is

- (A) 8 (B) 12 (C) 16 (D) 32

Q.7 If the signal $x(t) = \frac{\sin(t)}{\pi t} * \frac{\sin(t)}{\pi t}$ with $*$ denoting the convolution operation, then $x(t)$ is equal to

- (A) $\frac{\sin(t)}{\pi t}$ (B) $\frac{\sin(2t)}{2\pi t}$ (C) $\frac{2 \sin(t)}{\pi t}$ (D) $\left(\frac{\sin(t)}{\pi t}\right)^2$

Q.8 A discrete-time signal $x[n] = \delta[n - 3] + 2 \delta[n - 5]$ has z -transform $X(z)$. If $Y(z) = X(-z)$ is the z -transform of another signal $y[n]$, then

- (A) $y[n] = x[n]$
- (B) $y[n] = x[-n]$
- (C) $y[n] = -x[n]$
- (D) $y[n] = -x[-n]$

Q.9 In the RLC circuit shown in the figure, the input voltage is given by

$$v_i(t) = 2 \cos(200t) + 4 \sin(500t).$$

The output voltage $v_o(t)$ is

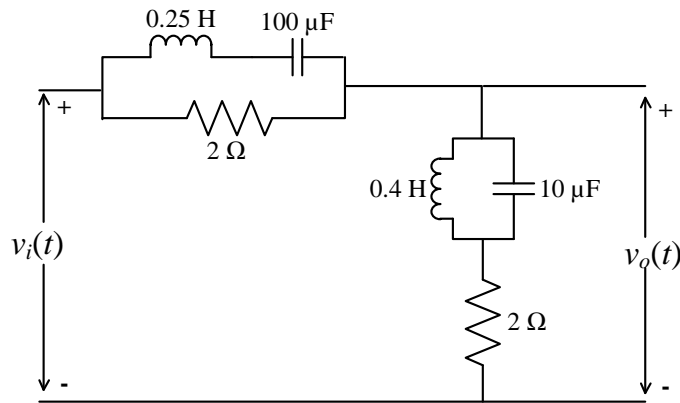

- (A) $\cos(200t) + 2 \sin(500t)$
- (B) $2\cos(200t) + 4 \sin(500t)$
- (C) $\sin(200t) + 2 \cos(500t)$
- (D) $2\sin(200t) + 4 \cos(500t)$

Q.10 The I-V characteristics of three types of diodes at the room temperature, made of semiconductors X, Y and Z, are shown in the figure. Assume that the diodes are uniformly doped and identical in all respects except their materials. If E_{gX} , E_{gY} and E_{gZ} are the band gaps of X, Y and Z, respectively, then

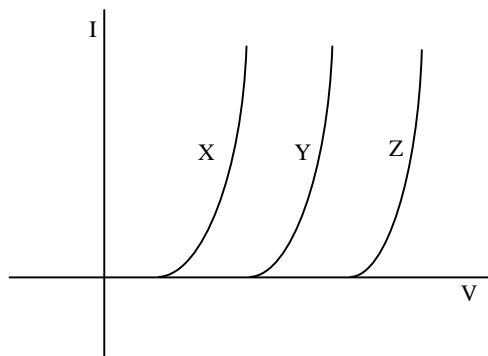

- (A) $E_{gX} > E_{gY} > E_{gZ}$
- (B) $E_{gX} = E_{gY} = E_{gZ}$
- (C) $E_{gX} < E_{gY} < E_{gZ}$
- (D) no relationship among these band gaps exists.

Q.11 The figure shows the band diagram of a Metal Oxide Semiconductor (MOS). The surface region of this MOS is in

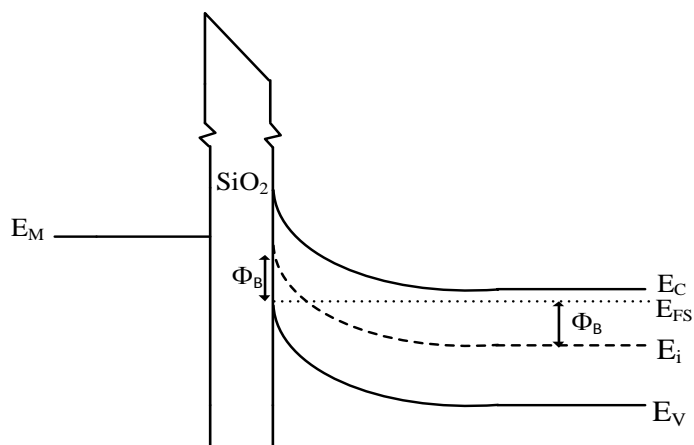

- (A) inversion (B) accumulation (C) depletion (D) flat band

Q.12 The figure shows the I-V characteristics of a solar cell illuminated uniformly with solar light of power 100 mW/cm^2 . The solar cell has an area of 3 cm^2 and a fill factor of 0.7. The maximum efficiency (in %) of the device is _____

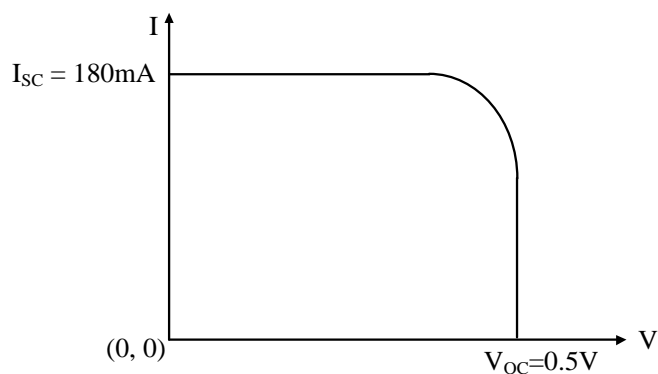

Q.13 The diodes D1 and D2 in the figure are ideal and the capacitors are identical. The product RC is very large compared to the time period of the ac voltage. Assuming that the diodes do not breakdown in the reverse bias, the output voltage V_o (in volt) at the steady state is _____

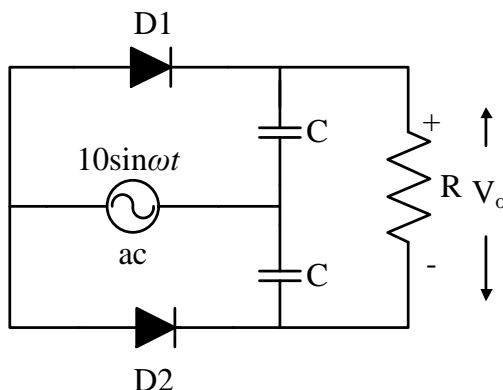

Q.14 Consider the circuit shown in the figure. Assuming $V_{BE1} = V_{EB2} = 0.7$ volt, the value of the dc voltage V_{C2} (in volt) is _____

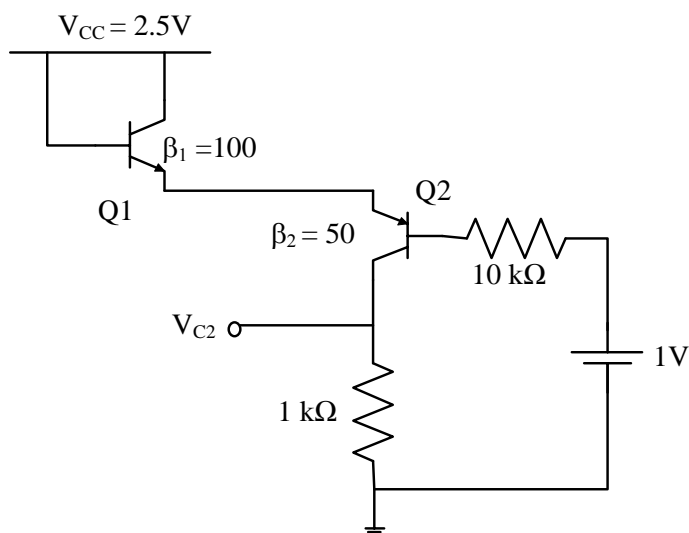

Q.15 In the astable multivibrator circuit shown in the figure, the frequency of oscillation (in kHz) at the output pin 3 is _____

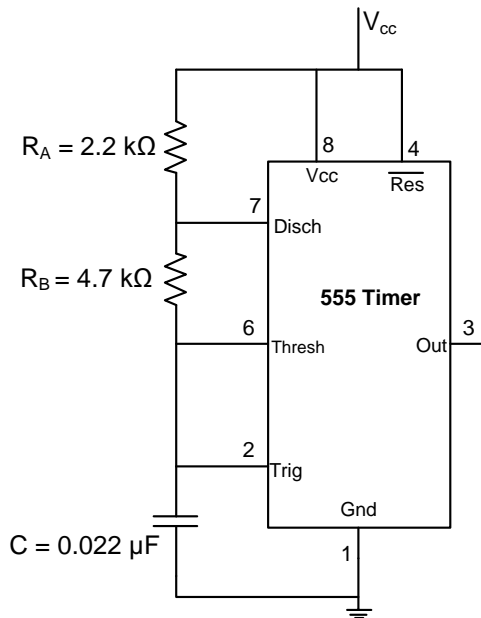

Q.16 In an 8085 microprocessor, the contents of the accumulator and the carry flag are A7 (in hex) and 0, respectively. If the instruction RLC is executed, then the contents of the accumulator (in hex) and the carry flag, respectively, will be

- (A) 4E and 0 (B) 4E and 1 (C) 4F and 0 (D) 4F and 1

Q.17 The logic functionality realized by the circuit shown below is

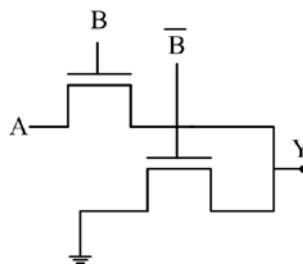

- (A) OR (B) XOR (C) NAND (D) AND

Q.18 The minimum number of 2-input NAND gates required to implement a 2-input XOR gate is

- (A) 4 (B) 5 (C) 6 (D) 7

Q.19 The block diagram of a feedback control system is shown in the figure. The overall closed-loop gain G of the system is

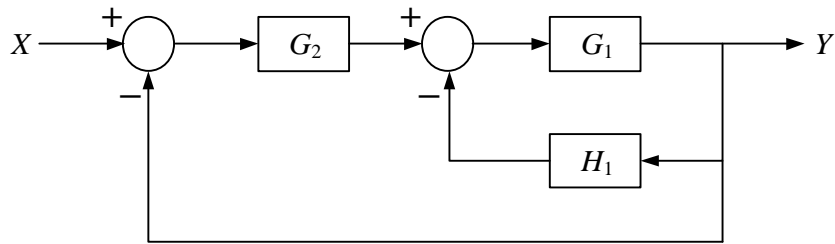

(A) $G = \frac{G_1 G_2}{1 + G_1 H_1}$

(B) $G = \frac{G_1 G_2}{1 + G_1 G_2 + G_1 H_1}$

(C) $G = \frac{G_1 G_2}{1 + G_1 G_2 H_1}$

(D) $G = \frac{G_1 G_2}{1 + G_1 G_2 + G_1 G_2 H_1}$

Q.20 For the unity feedback control system shown in the figure, the open-loop transfer function $G(s)$ is given as

$$G(s) = \frac{2}{s(s+1)}$$

The steady state error e_{ss} due to a unit step input is

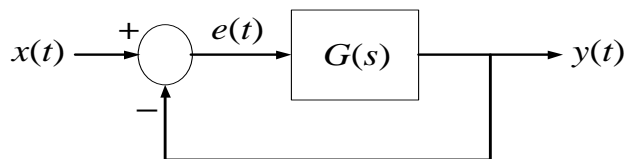

(A) 0

(B) 0.5

(C) 1.0

(D) ∞

Q.21 For a superheterodyne receiver, the intermediate frequency is 15 MHz and the local oscillator frequency is 3.5 GHz. If the frequency of the received signal is greater than the local oscillator frequency, then the image frequency (in MHz) is _____

Q.22 An analog baseband signal, bandlimited to 100 Hz, is sampled at the Nyquist rate. The samples are quantized into four message symbols that occur independently with probabilities $p_1 = p_4 = 0.125$ and $p_2 = p_3$. The information rate (bits/sec) of the message source is _____



Q.23 A binary baseband digital communication system employs the signal

$$p(t) = \begin{cases} \frac{1}{\sqrt{T_s}}, & 0 \leq t \leq T_s \\ 0, & \text{otherwise} \end{cases}$$

for transmission of bits. The graphical representation of the matched filter output $y(t)$ for this signal will be

(A)

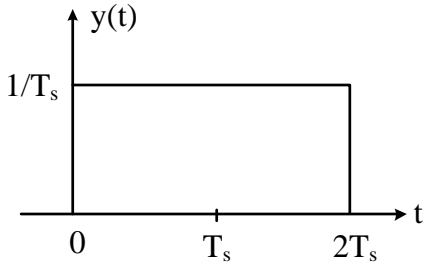

(B)

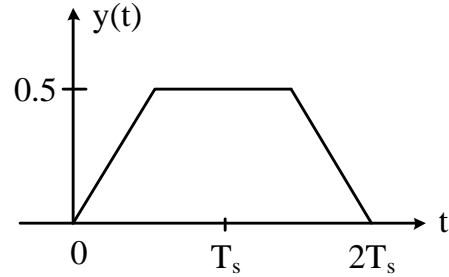

(C)

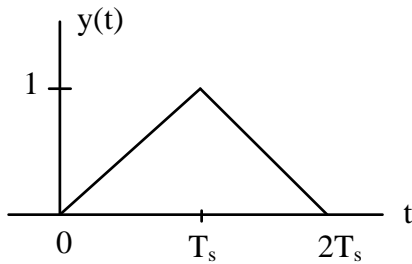

(D)

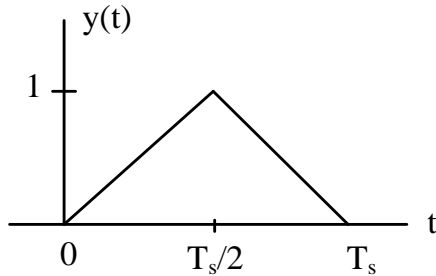

Q.24 If a right-handed circularly polarized wave is incident normally on a plane perfect conductor, then the reflected wave will be

- (A) right-handed circularly polarized
- (B) left-handed circularly polarized
- (C) elliptically polarized with a tilt angle of 45°
- (D) horizontally polarized

Q.25 Faraday's law of electromagnetic induction is mathematically described by which one of the following equations?

(A) $\nabla \cdot \vec{B} = 0$

(B) $\nabla \cdot \vec{D} = \rho_v$

(C) $\nabla \times \vec{E} = -\frac{\partial \vec{B}}{\partial t}$

(D) $\nabla \times \vec{H} = \sigma \vec{E} + \frac{\partial \vec{D}}{\partial t}$



Q.30 A signal $2 \cos\left(\frac{2\pi}{3}t\right) - \cos(\pi t)$ is the input to an LTI system with the transfer function

$$H(s) = e^s + e^{-s}.$$

If C_k denotes the k^{th} coefficient in the exponential Fourier series of the output signal, then C_3 is equal to

- (A) 0 (B) 1 (C) 2 (D) 3

Q.31 The ROC (region of convergence) of the z -transform of a discrete-time signal is represented by the shaded region in the z -plane. If the signal $x[n] = (2.0)^{|n|}$, $-\infty < n < +\infty$, then the ROC of its z -transform is represented by

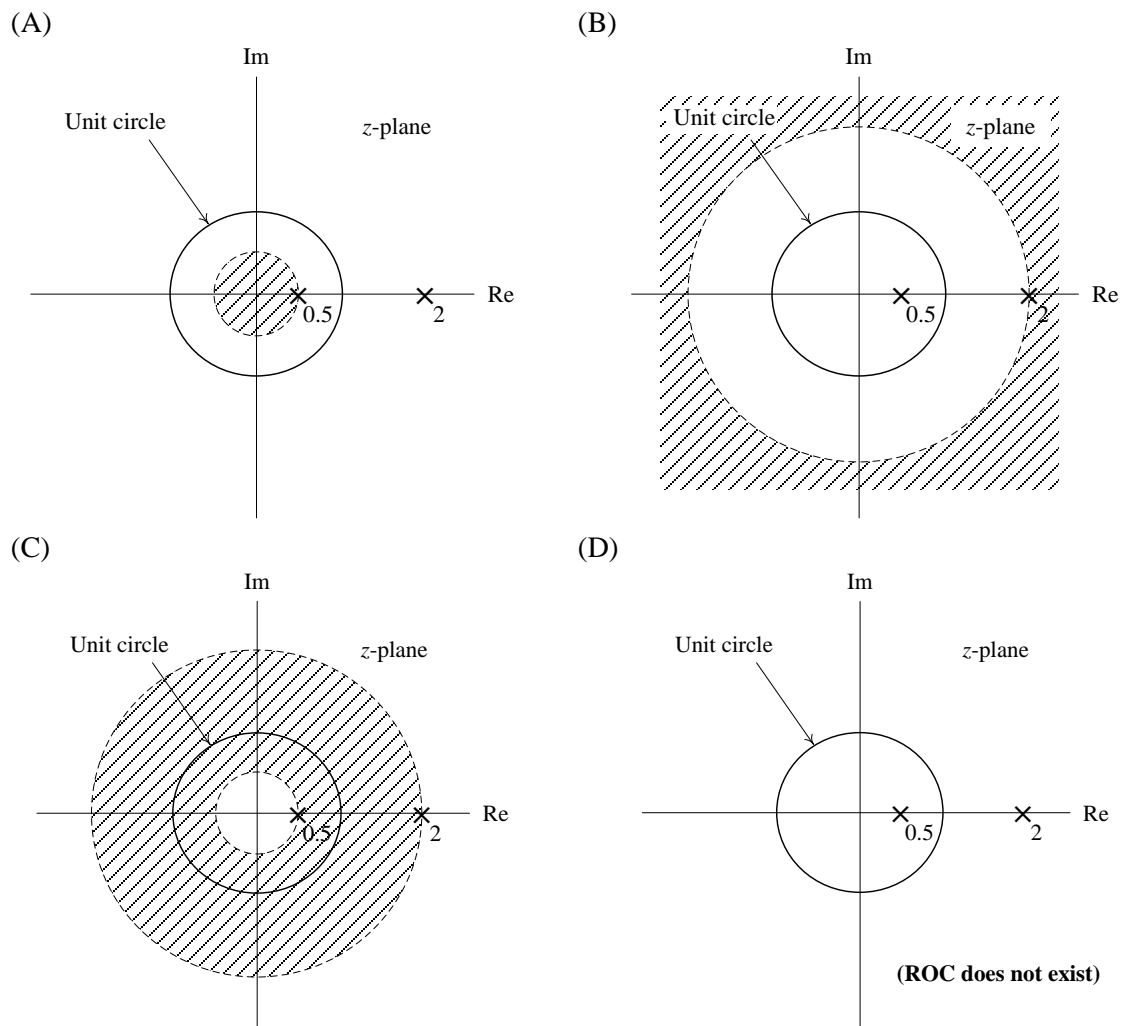

Q.32 Assume that the circuit in the figure has reached the steady state before time $t = 0$ when the 3Ω resistor suddenly burns out, resulting in an open circuit. The current $i(t)$ (in ampere) at $t = 0^+$ is _____

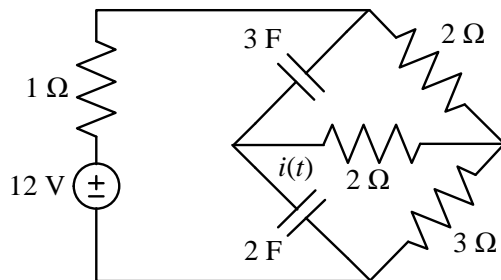

Q.33 In the figure shown, the current i (in ampere) is _____

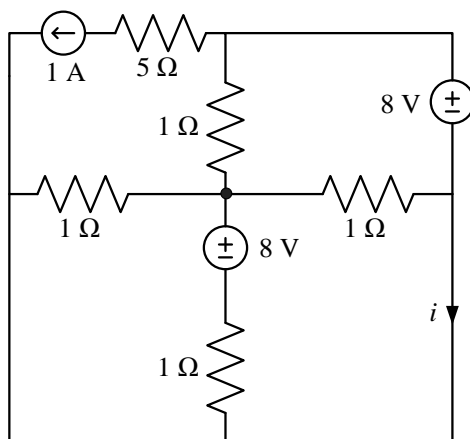

Q.34 The z-parameter matrix $\begin{bmatrix} z_{11} & z_{12} \\ z_{21} & z_{22} \end{bmatrix}$ for the two-port network shown is

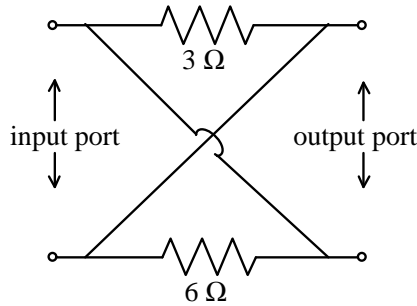

(A) $\begin{bmatrix} 2 & -2 \\ -2 & 2 \end{bmatrix}$

(B) $\begin{bmatrix} 2 & 2 \\ 2 & 2 \end{bmatrix}$

(C) $\begin{bmatrix} 9 & -3 \\ 6 & 9 \end{bmatrix}$

(D) $\begin{bmatrix} 9 & 3 \\ 6 & 9 \end{bmatrix}$

Q.35 A continuous-time speech signal $x_c(t)$ is sampled at a rate of 8 kHz and the samples are subsequently grouped in blocks, each of size N . The DFT of each block is to be computed in real time using the radix-2 decimation-in-frequency FFT algorithm. If the processor performs all operations sequentially, and takes $20 \mu\text{s}$ for computing each complex multiplication (including multiplications by 1 and -1) and the time required for addition/subtraction is negligible, then the maximum value of N is _____

Q.36 The direct form structure of an FIR (finite impulse response) filter is shown in the figure.

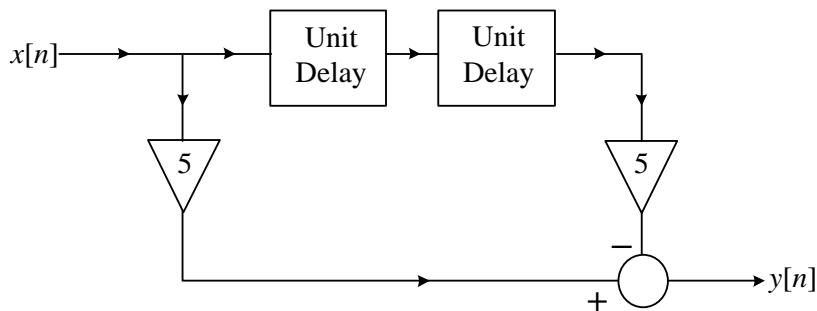

The filter can be used to approximate a

(A) low-pass filter

(B) high-pass filter

(C) band-pass filter

(D) band-stop filter

Q.37 The injected excess electron concentration profile in the base region of an *npn* BJT, biased in the active region, is linear, as shown in the figure. If the area of the emitter-base junction is 0.001 cm^2 , $\mu_n = 800 \text{ cm}^2/(\text{V}\cdot\text{s})$ in the base region and depletion layer widths are negligible, then the collector current I_C (in mA) at room temperature is _____

(Given: thermal voltage $V_T = 26 \text{ mV}$ at room temperature, electronic charge $q = 1.6 \times 10^{-19} \text{ C}$)

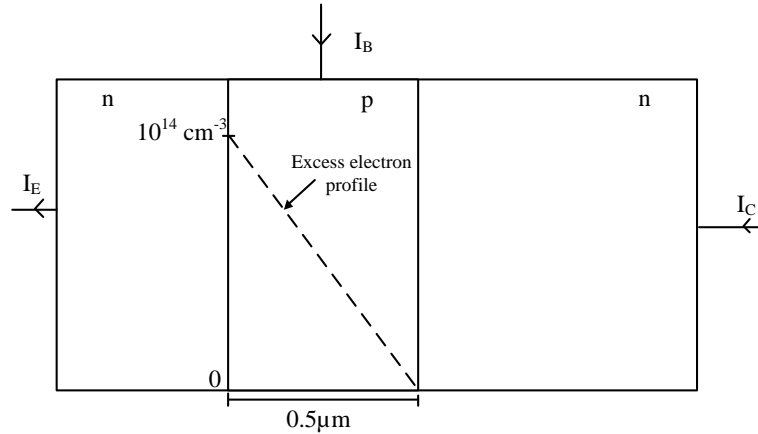

Q.38 Figures I and II show two MOS capacitors of unit area. The capacitor in Figure I has insulator materials X (of thickness $t_1 = 1 \text{ nm}$ and dielectric constant $\epsilon_1 = 4$) and Y (of thickness $t_2 = 3 \text{ nm}$ and dielectric constant $\epsilon_2 = 20$). The capacitor in Figure II has only insulator material X of thickness t_{Eq} . If the capacitors are of equal capacitance, then the value of t_{Eq} (in nm) is _____

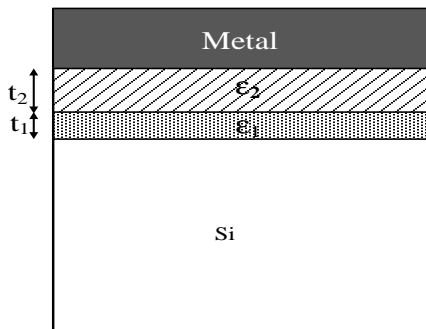

Figure I

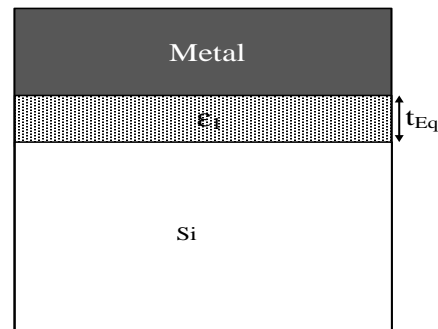
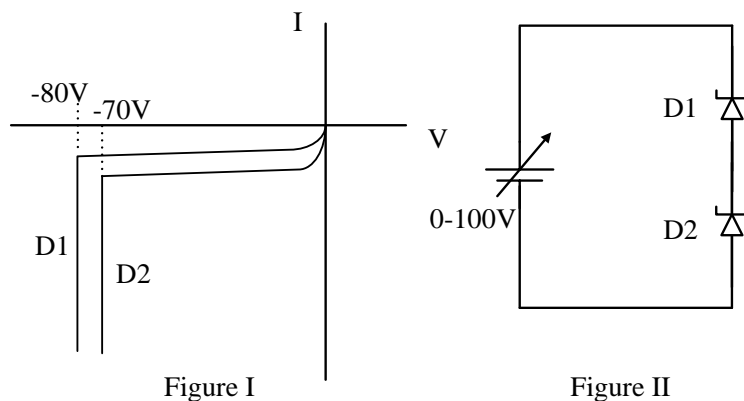

Figure II

Q.39 The I-V characteristics of the zener diodes D1 and D2 are shown in Figure I. These diodes are used in the circuit given in Figure II. If the supply voltage is varied from 0 to 100 V, then breakdown occurs in



- (A) D1 only
- (B) D2 only
- (C) both D1 and D2
- (D) none of D1 and D2

Q.40 For the circuit shown in the figure, $R_1 = R_2 = R_3 = 1 \Omega$, $L = 1 \mu\text{H}$ and $C = 1 \mu\text{F}$. If the input $V_{in} = \cos(10^6 t)$, then the overall voltage gain (V_{out}/V_{in}) of the circuit is _____

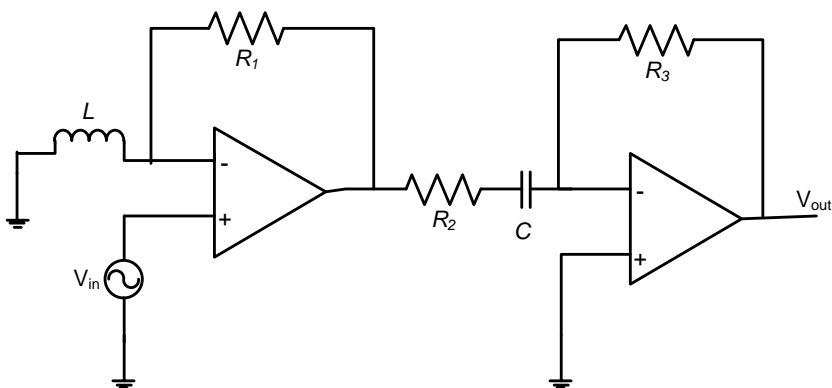

Q.41 In the circuit shown in the figure, the channel length modulation of all transistors is non-zero ($\lambda \neq 0$). Also, all transistors operate in saturation and have negligible body effect. The ac small signal voltage gain (V_o/V_{in}) of the circuit is

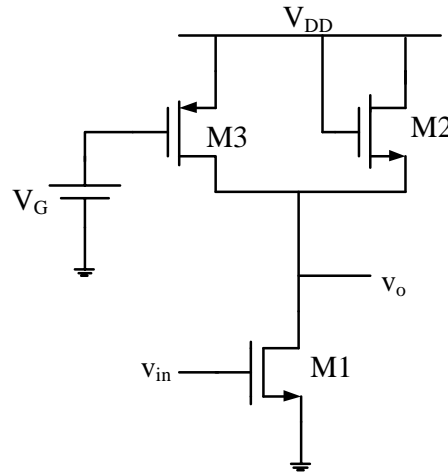

- (A) $-g_{m1}(r_{o1} || r_{o2} || r_{o3})$ (B) $-g_{m1}(r_{o1} || \frac{1}{g_{m3}} || r_{o3})$
 (C) $-g_{m1}(r_{o1} || (\frac{1}{g_{m2}} || r_{o2}) || r_{o3})$ (D) $-g_{m1}(r_{o1} || (\frac{1}{g_{m3}} || r_{o3}) || r_{o2})$

Q.42 In the circuit shown in the figure, transistor M1 is in saturation and has transconductance $g_m = 0.01$ siemens. Ignoring internal parasitic capacitances and assuming the channel length modulation λ to be zero, the small signal input pole frequency (in kHz) is _____

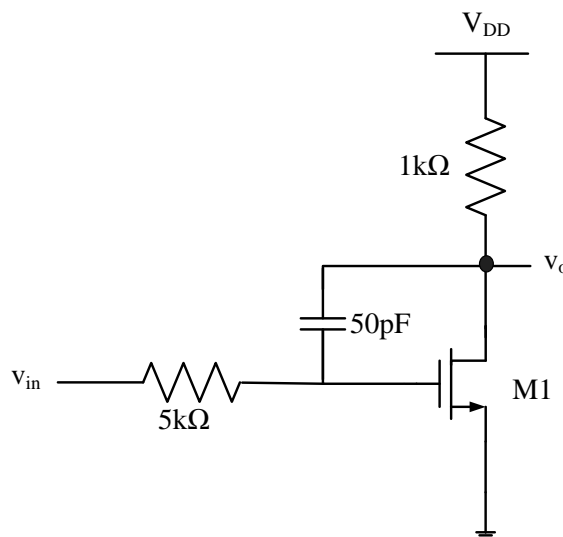

Q.43 Following is the K-map of a Boolean function of five variables P, Q, R, S and X. The minimum sum-of-product (SOP) expression for the function is

| | | | | |
|---------|----|----|----|----|
| RS \ PQ | 00 | 01 | 11 | 10 |
| | 00 | 0 | 0 | 0 |
| 01 | 1 | 0 | 0 | 1 |
| 11 | 1 | 0 | 0 | 1 |
| 10 | 0 | 0 | 0 | 0 |

X=0

| | | | | |
|---------|----|----|----|----|
| RS \ PQ | 00 | 01 | 11 | 10 |
| | 00 | 0 | 1 | 1 |
| 01 | 0 | 0 | 0 | 0 |
| 11 | 0 | 0 | 0 | 0 |
| 10 | 0 | 1 | 1 | 0 |

X=1

- (A) $\bar{P}\bar{Q}S\bar{X} + P\bar{Q}S\bar{X} + Q\bar{R}\bar{S}X + QR\bar{S}X$
- (B) $\bar{Q}S\bar{X} + Q\bar{S}X$
- (C) $\bar{Q}SX + Q\bar{S}\bar{X}$
- (D) $\bar{Q}S + Q\bar{S}$

Q.44 For the circuit shown in the figure, the delays of NOR gates, multiplexers and inverters are 2 ns, 1.5 ns and 1 ns, respectively. If all the inputs P, Q, R, S and T are applied at the same time instant, the maximum propagation delay (in ns) of the circuit is _____

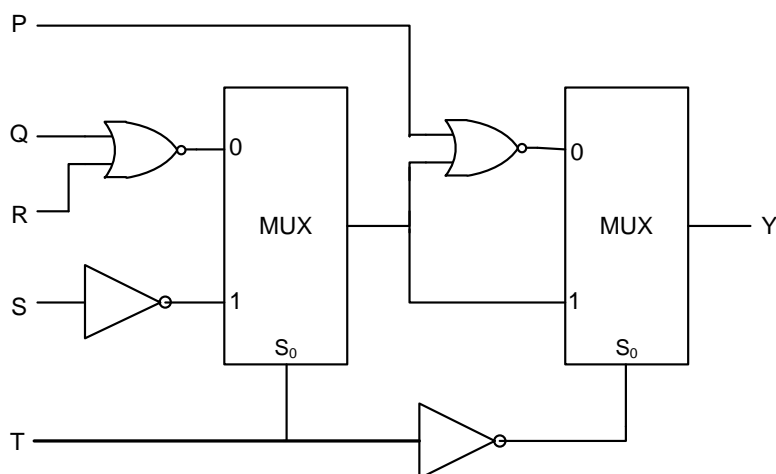

Q.45 For the circuit shown in the figure, the delay of the bubbled NAND gate is 2 ns and that of the counter is assumed to be zero.

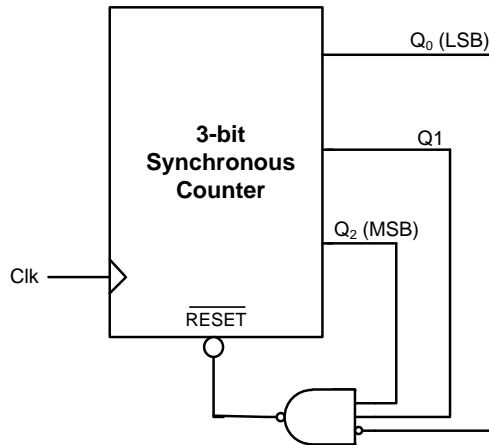

If the clock (Clk) frequency is 1 GHz, then the counter behaves as a

- (A) mod-5 counter (B) mod-6 counter (C) mod-7 counter (D) mod-8 counter

Q.46 The first two rows in the Routh table for the characteristic equation of a certain closed-loop control system are given as

| | | |
|-------|------|------------|
| s^3 | 1 | $(2K + 3)$ |
| s^2 | $2K$ | 4 |

The range of K for which the system is stable is

- (A) $-2.0 < K < 0.5$ (B) $0 < K < 0.5$ (C) $0 < K < \infty$ (D) $0.5 < K < \infty$

Q.47 A second-order linear time-invariant system is described by the following state equations

$$\frac{d}{dt} x_1(t) + 2x_1(t) = 3u(t)$$

$$\frac{d}{dt} x_2(t) + x_2(t) = u(t)$$

where $x_1(t)$ and $x_2(t)$ are the two state variables and $u(t)$ denotes the input. If the output $c(t) = x_1(t)$, then the system is

- (A) controllable but not observable
 (B) observable but not controllable
 (C) both controllable and observable
 (D) neither controllable nor observable

Q.48 The forward-path transfer function and the feedback-path transfer function of a single loop negative feedback control system are given as

$$G(s) = \frac{K(s+2)}{s^2 + 2s + 2} \quad \text{and} \quad H(s) = 1,$$

respectively. If the variable parameter K is real positive, then the location of the breakaway point on the root locus diagram of the system is _____

Q.49 A wide sense stationary random process $X(t)$ passes through the LTI system shown in the figure. If the autocorrelation function of $X(t)$ is $R_X(\tau)$, then the autocorrelation function $R_Y(\tau)$ of the output $Y(t)$ is equal to

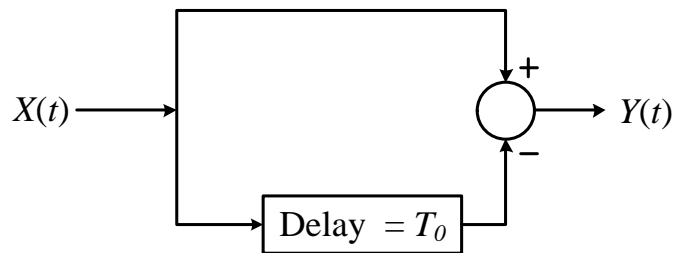

- (A) $2R_X(\tau) + R_X(\tau - T_0) + R_X(\tau + T_0)$ (B) $2R_X(\tau) - R_X(\tau - T_0) - R_X(\tau + T_0)$
 (C) $2R_X(\tau) + 2R_X(\tau - 2T_0)$ (D) $2R_X(\tau) - 2R_X(\tau - 2T_0)$

Q.50 A voice-grade AWGN (additive white Gaussian noise) telephone channel has a bandwidth of 4.0 kHz and two-sided noise power spectral density $\frac{\eta}{2} = 2.5 \times 10^{-5}$ Watt per Hz. If information at the rate of 52 kbps is to be transmitted over this channel with arbitrarily small bit error rate, then the minimum bit-energy E_b (in mJ/bit) necessary is _____

Q.51 The bit error probability of a memoryless binary symmetric channel is 10^{-5} . If 10^5 bits are sent over this channel, then the probability that not more than one bit will be in error is _____

Q.52 Consider an air-filled rectangular waveguide with dimensions $a = 2.286$ cm and $b = 1.016$ cm. At 10 GHz operating frequency, the value of the propagation constant (per meter) of the corresponding propagating mode is _____

Q.53 Consider an air-filled rectangular waveguide with dimensions $a = 2.286$ cm and $b = 1.016$ cm. The increasing order of the cut-off frequencies for different modes is

(A) $TE_{01} < TE_{10} < TE_{11} < TE_{20}$

(B) $TE_{20} < TE_{11} < TE_{10} < TE_{01}$

(C) $TE_{10} < TE_{20} < TE_{01} < TE_{11}$

(D) $TE_{10} < TE_{11} < TE_{20} < TE_{01}$

Q.54 A radar operating at 5 GHz uses a common antenna for transmission and reception. The antenna has a gain of 150 and is aligned for maximum directional radiation and reception to a target 1 km away having radar cross-section of 3 m^2 . If it transmits 100 kW, then the received power (in μW) is _____

Q.55 Consider the charge profile shown in the figure. The resultant potential distribution is best described by

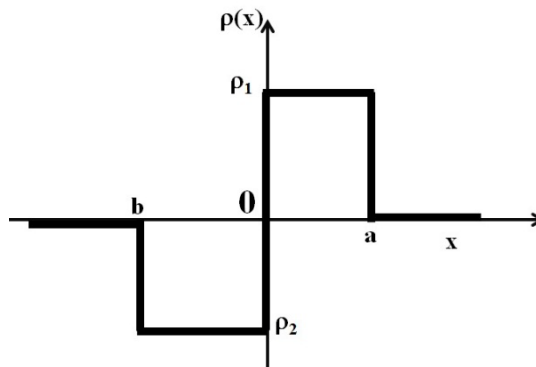

(A)

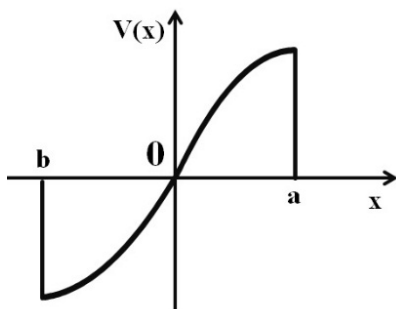

(B)

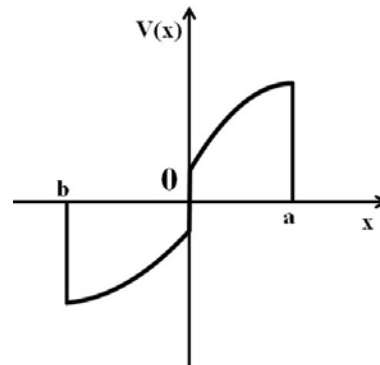

(C)

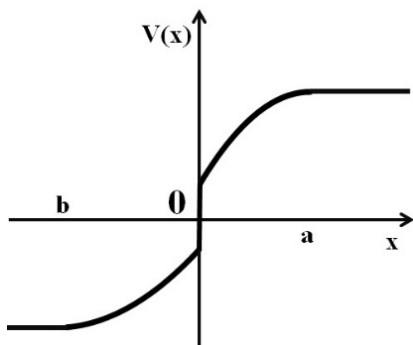

(D)

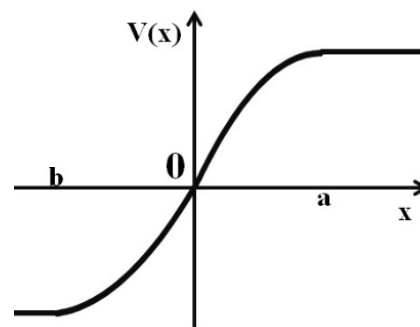

END OF THE QUESTION PAPER

| Q. No | Type | Section | Key | Marks |
|-------|------|---------|---|-------|
| 1 | MCQ | GA | C | 1 |
| 2 | MCQ | GA | C | 1 |
| 3 | MCQ | GA | B | 1 |
| 4 | MCQ | GA | C ; D | 1 |
| 5 | MCQ | GA | A | 1 |
| 6 | MCQ | GA | D | 2 |
| 7 | MCQ | GA | A | 2 |
| 8 | MCQ | GA | C | 2 |
| 9 | MCQ | GA | B | 2 |
| 10 | MCQ | GA | A | 2 |
| 1 | MCQ | EC-3 | D | 1 |
| 2 | NAT | EC-3 | 1.0 : 1.0 | 1 |
| 3 | NAT | EC-3 | 0.07 : 0.08 | 1 |
| 4 | NAT | EC-3 | 2.0 : 2.0 | 1 |
| 5 | NAT | EC-3 | 0.060 : 0.063 | 1 |
| 6 | MCQ | EC-3 | C | 1 |
| 7 | MCQ | EC-3 | A | 1 |
| 8 | MCQ | EC-3 | C | 1 |
| 9 | MCQ | EC-3 | B | 1 |
| 10 | MCQ | EC-3 | C | 1 |
| 11 | MCQ | EC-3 | A | 1 |
| 12 | NAT | EC-3 | 20.5 : 21.5 | 1 |
| 13 | NAT | EC-3 | 0.0 : 0.0 | 1 |
| 14 | NAT | EC-3 | 0.45 : 0.55 | 1 |
| 15 | NAT | EC-3 | 5.55 : 5.75 | 1 |
| 16 | MCQ | EC-3 | D | 1 |
| 17 | MCQ | EC-3 | D | 1 |
| 18 | MCQ | EC-3 | A | 1 |
| 19 | MCQ | EC-3 | B | 1 |
| 20 | MCQ | EC-3 | A | 1 |
| 21 | NAT | EC-3 | 3485 : 3485 | 1 |
| 22 | NAT | EC-3 | 360 : 363 | 1 |
| 23 | MCQ | EC-3 | C | 1 |
| 24 | MCQ | EC-3 | B | 1 |
| 25 | MCQ | EC-3 | C | 1 |
| 26 | MCQ | EC-3 | A | 2 |
| 27 | MCQ | EC-3 | D | 2 |
| 28 | NAT | EC-3 | 10.0 : 10.0 | 2 |
| 29 | MCQ | EC-3 | B | 2 |
| 30 | MCQ | EC-3 | B | 2 |
| 31 | MCQ | EC-3 | D | 2 |
| 32 | NAT | EC-3 | 0.98 : 1.02 ; -1.02 : -0.98 ; 1.96 : 2.04 ; -2.04 : -1.96 | 2 |
| 33 | NAT | EC-3 | -1.05 : -0.95 | 2 |
| 34 | MCQ | EC-3 | A | 2 |
| 35 | NAT | EC-3 | 4096 : 4096 | 2 |
| 36 | MCQ | EC-3 | C | 2 |
| 37 | NAT | EC-3 | 6.55 : 6.75 | 2 |
| 38 | NAT | EC-3 | 1.55 : 1.65 | 2 |
| 39 | MCQ | EC-3 | A | 2 |



| | | | | |
|----|-----|------|---------------|---|
| 40 | NAT | EC-3 | -1.0 : -1.0 | 2 |
| 41 | MCQ | EC-3 | C | 2 |
| 42 | NAT | EC-3 | 56 : 63 | 2 |
| 43 | MCQ | EC-3 | B | 2 |
| 44 | NAT | EC-3 | 6.0 : 6.0 | 2 |
| 45 | MCQ | EC-3 | D | 2 |
| 46 | MCQ | EC-3 | D | 2 |
| 47 | MCQ | EC-3 | A | 2 |
| 48 | NAT | EC-3 | -3.45 : -3.35 | 2 |
| 49 | MCQ | EC-3 | B | 2 |
| 50 | NAT | EC-3 | 30.0 : 33.0 | 2 |
| 51 | NAT | EC-3 | 0.70 : 0.75 | 2 |
| 52 | NAT | EC-3 | 155.0 : 162.0 | 2 |
| 53 | MCQ | EC-3 | C | 2 |
| 54 | NAT | EC-3 | 0.01 : 0.02 | 2 |
| 55 | MCQ | EC-3 | D | 2 |

