



EC : ELECTRONICS AND COMMUNICATION ENGINEERING

Duration: Three Hours

Maximum Marks: 100

Read the following instructions carefully.

1. Do not open the seal of the Question Booklet until you are asked to do so by the invigilator.
2. Take out the **Optical Response Sheet (ORS)** from this Question Booklet **without breaking the seal** and read the instructions printed on the **ORS** carefully. If you find that the Question Booklet Code printed at the right hand top corner of this page does not match with the Booklet Code on the **ORS**, exchange the booklet immediately with a new sealed Question Booklet.
3. On the right half of the **ORS**, using **ONLY a black ink ball point pen**, (i) darken the bubble corresponding to your test paper code and the appropriate bubble under each digit of your registration number and (ii) write your registration number, your name and name of the examination centre and put your signature at the specified location.
4. This Question Booklet contains **20** pages including blank pages for rough work. After you are permitted to open the seal, please check all pages and report discrepancies, if any, to the invigilator.
5. There are a total of 65 questions carrying 100 marks. All these questions are of objective type. Each question has only **one** correct answer. Questions must be answered on the left hand side of the **ORS** by darkening the appropriate bubble (marked A, B, C, D) using **ONLY a black ink ball point pen** against the question number. **For each question darken the bubble of the correct answer.** More than one answer bubbled against a question will be treated as an incorrect response.
6. Since bubbles darkened by the black ink ball point pen **cannot** be erased, candidates should darken the bubbles in the **ORS very carefully.**
7. Questions Q.1 – Q.25 carry 1 mark each. Questions Q.26 – Q.55 carry 2 marks each. The 2 marks questions include two pairs of common data questions and two pairs of linked answer questions. The answer to the second question of the linked answer questions depends on the answer to the first question of the pair. If the first question in the linked pair is wrongly answered or is unattempted, then the answer to the second question in the pair will not be evaluated.
8. Questions Q.56 – Q.65 belong to General Aptitude (GA) section and carry a total of 15 marks. Questions Q.56 – Q.60 carry 1 mark each, and questions Q.61 – Q.65 carry 2 marks each.
9. Unattempted questions will result in zero mark and wrong answers will result in **NEGATIVE** marks. For all 1 mark questions, $\frac{1}{3}$ mark will be deducted for each wrong answer. For all 2 marks questions, $\frac{2}{3}$ mark will be deducted for each wrong answer. However, in the case of the linked answer question pair, there will be negative marks only for wrong answer to the first question and no negative marks for wrong answer to the second question.
10. Calculator is allowed whereas charts, graph sheets or tables are **NOT** allowed in the examination hall.
11. Rough work can be done on the question paper itself. Blank pages are provided at the end of the question paper for rough work.
12. Before the start of the examination, write your name and registration number in the space provided below using a black ink ball point pen.

Name							
Registration Number	EC						



Q. 1 – Q. 25 carry one mark each.

- Q.1 The current i_b through the base of a silicon *npn* transistor is $1 + 0.1 \cos(10000\pi t)$ mA. At 300 K, the r_π in the small signal model of the transistor is

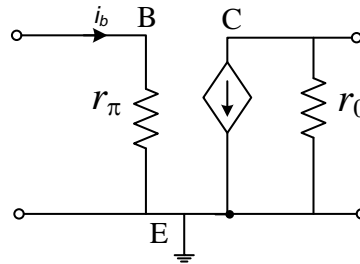

- (A) 250 Ω (B) 27.5 Ω (C) 25 Ω (D) 22.5 Ω
- Q.2 The power spectral density of a real process $X(t)$ for positive frequencies is shown below. The values of $E[X^2(t)]$ and $|E[X(t)]|$, respectively, are

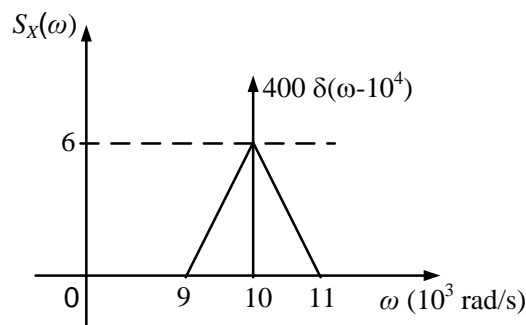

- (A) $6000/\pi, 0$ (B) $6400/\pi, 0$
 (C) $6400/\pi, 20/(\pi\sqrt{2})$ (D) $6000/\pi, 20/(\pi\sqrt{2})$
- Q.3 In a baseband communications link, frequencies upto 3500 Hz are used for signaling. Using a raised cosine pulse with 75% excess bandwidth and for no inter-symbol interference, the maximum possible signaling rate in symbols per second is
- (A) 1750 (B) 2625 (C) 4000 (D) 5250
- Q.4 A plane wave propagating in air with $\vec{E} = (8\hat{a}_x + 6\hat{a}_y + 5\hat{a}_z)e^{j(\omega t + 3x + 4y)}$ V/m is incident on a perfectly conducting slab positioned at $x \leq 0$. The \vec{E} field of the reflected wave is
- (A) $(-8\hat{a}_x - 6\hat{a}_y - 5\hat{a}_z)e^{j(\omega t + 3x + 4y)}$ V/m
 (B) $(-8\hat{a}_x + 6\hat{a}_y - 5\hat{a}_z)e^{j(\omega t + 3x + 4y)}$ V/m
 (C) $(-8\hat{a}_x - 6\hat{a}_y - 5\hat{a}_z)e^{j(\omega t - 3x - 4y)}$ V/m
 (D) $(-8\hat{a}_x + 6\hat{a}_y - 5\hat{a}_z)e^{j(\omega t - 3x - 4y)}$ V/m
- Q.5 The electric field of a uniform plane electromagnetic wave in free space, along the positive x direction, is given by $\vec{E} = 10(\hat{a}_y + j\hat{a}_z)e^{-j25x}$. The frequency and polarization of the wave, respectively, are
- (A) 1.2 GHz and left circular (B) 4 Hz and left circular
 (C) 1.2 GHz and right circular (D) 4 Hz and right circular

Q.6 Consider the given circuit.

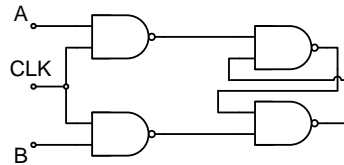

In this circuit, the race around

- (A) does not occur (B) occurs when CLK = 0
 (C) occurs when CLK = 1 and A = B = 1 (D) occurs when CLK = 1 and A = B = 0

Q.7 The output Y of a 2-bit comparator is logic 1 whenever the 2-bit input A is greater than the 2-bit input B. The number of combinations for which the output is logic 1, is

- (A) 4 (B) 6 (C) 8 (D) 10

Q.8 The i - v characteristics of the diode in the circuit given below are

$$i = \begin{cases} \frac{v-0.7}{500} \text{ A, } v \geq 0.7 \text{ V} \\ 0 \text{ A, } v < 0.7 \text{ V} \end{cases}$$

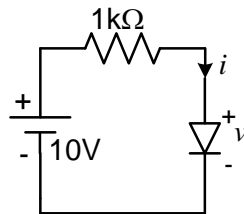

The current in the circuit is

- (A) 10 mA (B) 9.3 mA (C) 6.67 mA (D) 6.2 mA

Q.9 In the following figure, C_1 and C_2 are ideal capacitors. C_1 has been charged to 12 V before the ideal switch S is closed at $t = 0$. The current $i(t)$ for all t is

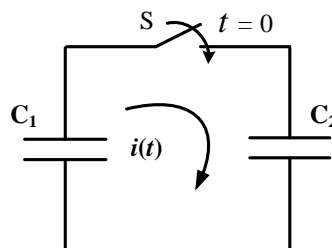

- (A) zero (B) a step function
 (C) an exponentially decaying function (D) an impulse function

Q.10 The average power delivered to an impedance $(4 - j3) \Omega$ by a current $5\cos(100\pi t + 100)$ A is

- (A) 44.2 W (B) 50 W (C) 62.5 W (D) 125 W

Q.11 The unilateral Laplace transform of $f(t)$ is $\frac{1}{s^2 + s + 1}$. The unilateral Laplace transform of $tf(t)$ is

- (A) $-\frac{s}{(s^2 + s + 1)^2}$ (B) $-\frac{2s + 1}{(s^2 + s + 1)^2}$
 (C) $\frac{s}{(s^2 + s + 1)^2}$ (D) $\frac{2s + 1}{(s^2 + s + 1)^2}$

Q.12 With initial condition $x(1) = 0.5$, the solution of the differential equation,

$$t \frac{dx}{dt} + x = t \text{ is}$$

- (A) $x = t - \frac{1}{2}$ (B) $x = t^2 - \frac{1}{2}$ (C) $x = \frac{t^2}{2}$ (D) $x = \frac{t}{2}$

Q.13 The diodes and capacitors in the circuit shown are ideal. The voltage $v(t)$ across the diode D1 is

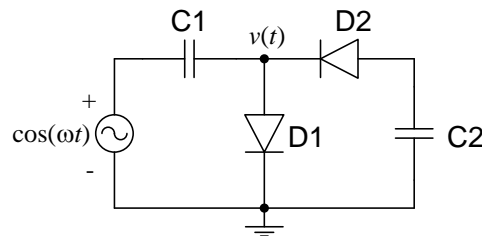

- (A) $\cos(\omega t) - 1$ (B) $\sin(\omega t)$ (C) $1 - \cos(\omega t)$ (D) $1 - \sin(\omega t)$

Q.14 In the circuit shown

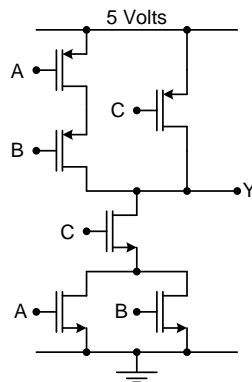

- (A) $Y = \overline{A}\overline{B} + \overline{C}$ (B) $Y = (A + B)C$
 (C) $Y = (\overline{A} + \overline{B})\overline{C}$ (D) $Y = AB + C$

Q.15 A source alphabet consists of N symbols with the probability of the first two symbols being the same. A source encoder increases the probability of the first symbol by a small amount ε and decreases that of the second by ε . After encoding, the entropy of the source

- (A) increases (B) remains the same
 (C) increases only if $N = 2$ (D) decreases

Q.16 A coaxial cable with an inner diameter of 1 mm and outer diameter of 2.4 mm is filled with a dielectric of relative permittivity 10.89. Given $\mu_0 = 4\pi \times 10^{-7}$ H/m, $\varepsilon_0 = \frac{10^{-9}}{36\pi}$ F/m, the characteristic impedance of the cable is

- (A) 330Ω (B) 100Ω (C) 143.3Ω (D) 43.4Ω

Q.17 The radiation pattern of an antenna in spherical co-ordinates is given by

$$F(\theta) = \cos^4 \theta; \quad 0 \leq \theta \leq \pi/2$$

The directivity of the antenna is

- (A) 10 dB (B) 12.6 dB (C) 11.5 dB (D) 18 dB

Q.18 If $x[n] = (1/3)^{|n|} - (1/2)^n u[n]$, then the region of convergence (ROC) of its Z-transform in the Z-plane will be

- (A) $\frac{1}{3} < |z| < 3$ (B) $\frac{1}{3} < |z| < \frac{1}{2}$ (C) $\frac{1}{2} < |z| < 3$ (D) $\frac{1}{3} < |z|$

Q.19 In the sum of products function $f(X, Y, Z) = \sum(2, 3, 4, 5)$, the prime implicants are

- (A) $\bar{X}Y, X\bar{Y}$ (B) $\bar{X}Y, X\bar{Y}\bar{Z}, X\bar{Y}Z$
 (C) $\bar{X}Y\bar{Z}, \bar{X}YZ, X\bar{Y}$ (D) $\bar{X}Y\bar{Z}, \bar{X}YZ, X\bar{Y}\bar{Z}, X\bar{Y}Z$

Q.20 A system with transfer function

$$G(s) = \frac{(s^2 + 9)(s + 2)}{(s + 1)(s + 3)(s + 4)}$$

is excited by $\sin(\omega t)$. The steady-state output of the system is zero at

- (A) $\omega = 1$ rad/s (B) $\omega = 2$ rad/s
 (C) $\omega = 3$ rad/s (D) $\omega = 4$ rad/s

Q.21 The impedance looking into nodes 1 and 2 in the given circuit is

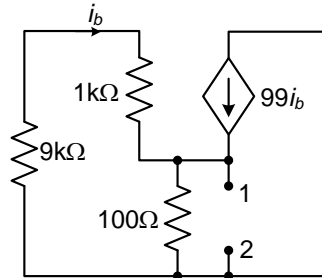

- (A) 50 Ω (B) 100 Ω (C) 5 kΩ (D) 10.1 kΩ

Q.22 In the circuit shown below, the current through the inductor is

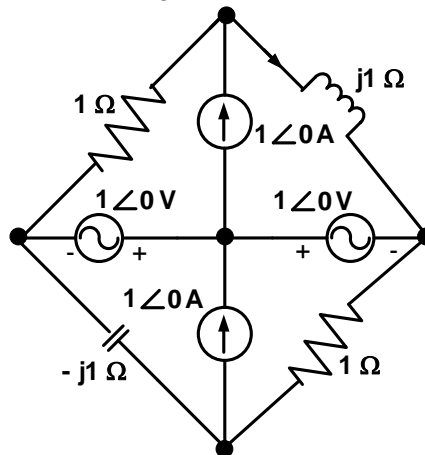

- (A) $\frac{2}{1+j}$ A (B) $\frac{-1}{1+j}$ A (C) $\frac{1}{1+j}$ A (D) 0 A

Q.23 Given

$f(z) = \frac{1}{z+1} - \frac{2}{z+3}$. If C is a counterclockwise path in the z -plane such that $|z+1|=1$, the value of

$$\frac{1}{2\pi j} \oint_C f(z) dz$$

- (A) -2 (B) -1 (C) 1 (D) 2

- Q.24 Two independent random variables X and Y are uniformly distributed in the interval $[-1, 1]$. The probability that $\max[X, Y]$ is less than $1/2$ is
- (A) $3/4$ (B) $9/16$ (C) $1/4$ (D) $2/3$
- Q.25 If $x = \sqrt{-1}$, then the value of x^x is
- (A) $e^{-\pi/2}$ (B) $e^{\pi/2}$ (C) x (D) 1

Q. 26 to Q. 55 carry two marks each.

- Q.26 The source of a silicon ($n_i = 10^{10}$ per cm^3) n-channel MOS transistor has an area of $1 \text{ sq } \mu\text{m}$ and a depth of $1 \text{ } \mu\text{m}$. If the dopant density in the source is $10^{19}/\text{cm}^3$, the number of holes in the source region with the above volume is approximately
- (A) 10^7 (B) 100 (C) 10 (D) 0
- Q.27 A BPSK scheme operating over an AWGN channel with noise power spectral density of $N_0/2$, uses equiprobable signals $s_1(t) = \sqrt{\frac{2E}{T}} \sin(\omega_c t)$ and $s_2(t) = -\sqrt{\frac{2E}{T}} \sin(\omega_c t)$ over the symbol interval $(0, T)$. If the local oscillator in a coherent receiver is ahead in phase by 45° with respect to the received signal, the probability of error in the resulting system is
- (A) $Q\left(\sqrt{\frac{2E}{N_0}}\right)$ (B) $Q\left(\sqrt{\frac{E}{N_0}}\right)$ (C) $Q\left(\sqrt{\frac{E}{2N_0}}\right)$ (D) $Q\left(\sqrt{\frac{E}{4N_0}}\right)$
- Q.28 A transmission line with a characteristic impedance of $100 \text{ } \Omega$ is used to match a $50 \text{ } \Omega$ section to a $200 \text{ } \Omega$ section. If the matching is to be done both at 429 MHz and 1 GHz , the length of the transmission line can be approximately
- (A) 82.5 cm (B) 1.05 m (C) 1.58 m (D) 1.75 m
- Q.29 The input $x(t)$ and output $y(t)$ of a system are related as $y(t) = \int_{-\infty}^t x(\tau) \cos(3\tau) d\tau$. The system is
- (A) time-invariant and stable (B) stable and not time-invariant
(C) time-invariant and not stable (D) not time-invariant and not stable

- Q.30 The feedback system shown below oscillates at 2 rad/s when

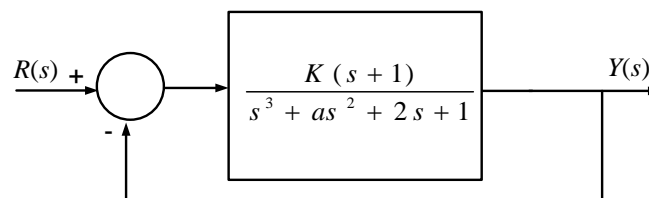

- (A) $K = 2$ and $a = 0.75$ (B) $K = 3$ and $a = 0.75$
(C) $K = 4$ and $a = 0.5$ (D) $K = 2$ and $a = 0.5$
- Q.31 The Fourier transform of a signal $h(t)$ is $H(j\omega) = (2\cos\omega)(\sin 2\omega)/\omega$. The value of $h(0)$ is
- (A) $1/4$ (B) $1/2$ (C) 1 (D) 2

Q.32 The state variable description of an LTI system is given by

$$\begin{pmatrix} \dot{x}_1 \\ \dot{x}_2 \\ \dot{x}_3 \end{pmatrix} = \begin{pmatrix} 0 & a_1 & 0 \\ 0 & 0 & a_2 \\ a_3 & 0 & 0 \end{pmatrix} \begin{pmatrix} x_1 \\ x_2 \\ x_3 \end{pmatrix} + \begin{pmatrix} 0 \\ 0 \\ 1 \end{pmatrix} u$$

$$y = (1 \ 0 \ 0) \begin{pmatrix} x_1 \\ x_2 \\ x_3 \end{pmatrix}$$

where y is the output and u is the input. The system is controllable for

- (A) $a_1 \neq 0, a_2 = 0, a_3 \neq 0$ (B) $a_1 = 0, a_2 \neq 0, a_3 \neq 0$
 (C) $a_1 = 0, a_2 \neq 0, a_3 = 0$ (D) $a_1 \neq 0, a_2 \neq 0, a_3 = 0$

Q.33 Assuming both the voltage sources are in phase, the value of R for which maximum power is transferred from circuit A to circuit B is

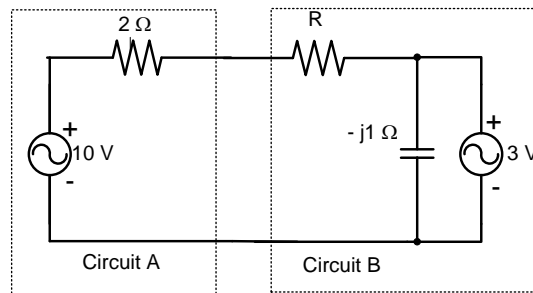

- (A) 0.8Ω (B) 1.4Ω (C) 2Ω (D) 2.8Ω

Q.34 Consider the differential equation

$$\frac{d^2 y(t)}{dt^2} + 2 \frac{dy(t)}{dt} + y(t) = \delta(t) \text{ with } y(t)|_{t=0^-} = -2 \text{ and } \frac{dy}{dt}|_{t=0^-} = 0.$$

The numerical value of $\frac{dy}{dt}|_{t=0^+}$ is

- (A) -2 (B) -1 (C) 0 (D) 1

Q.35 The direction of vector \mathbf{A} is radially outward from the origin, with $|\mathbf{A}| = k r^n$ where $r^2 = x^2 + y^2 + z^2$ and k is a constant. The value of n for which $\nabla \cdot \mathbf{A} = \mathbf{0}$ is

- (A) -2 (B) 2 (C) 1 (D) 0

Q.36 A fair coin is tossed till a head appears for the first time. The probability that the number of required tosses is odd, is

- (A) $1/3$ (B) $1/2$ (C) $2/3$ (D) $3/4$

- Q.37 In the CMOS circuit shown, electron and hole mobilities are equal, and M1 and M2 are equally sized. The device M1 is in the linear region if

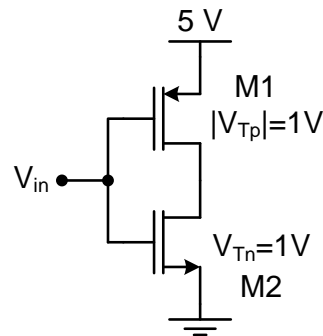

- (A) $V_{in} < 1.875 \text{ V}$
 (B) $1.875 \text{ V} < V_{in} < 3.125 \text{ V}$
 (C) $V_{in} > 3.125 \text{ V}$
 (D) $0 < V_{in} < 5 \text{ V}$
- Q.38 A binary symmetric channel (BSC) has a transition probability of $1/8$. If the binary transmit symbol X is such that $P(X=0) = 9/10$, then the probability of error for an optimum receiver will be
- (A) $7/80$ (B) $63/80$ (C) $9/10$ (D) $1/10$
- Q.39 The signal $m(t)$ as shown is applied both to a phase modulator (with k_p as the phase constant) and a frequency modulator (with k_f as the frequency constant) having the same carrier frequency.

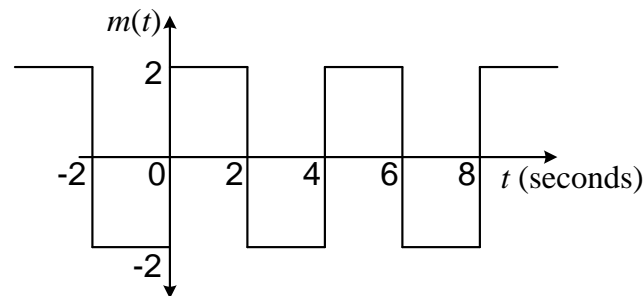

The ratio k_p/k_f (in rad/Hz) for the same maximum phase deviation is

- (A) 8π (B) 4π (C) 2π (D) π
- Q.40 The magnetic field along the propagation direction inside a rectangular waveguide with the cross-section shown in the figure is

$$H_z = 3 \cos(2.094 \times 10^2 x) \cos(2.618 \times 10^2 y) \cos(6.283 \times 10^{10} t - \beta z)$$

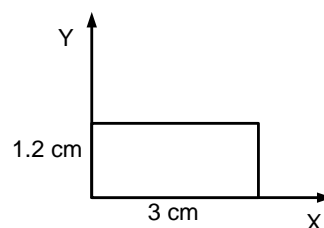

The phase velocity v_p of the wave inside the waveguide satisfies

- (A) $v_p > c$ (B) $v_p = c$ (C) $0 < v_p < c$ (D) $v_p = 0$

Q.41 The circuit shown is a

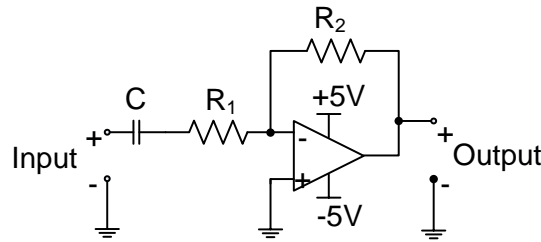

- (A) low pass filter with $f_{3dB} = \frac{1}{(R_1 + R_2)C}$ rad/s
- (B) high pass filter with $f_{3dB} = \frac{1}{R_1 C}$ rad/s
- (C) low pass filter with $f_{3dB} = \frac{1}{R_1 C}$ rad/s
- (D) high pass filter with $f_{3dB} = \frac{1}{(R_1 + R_2)C}$ rad/s

Q.42 Let $y[n]$ denote the convolution of $h[n]$ and $g[n]$, where $h[n] = (1/2)^n u[n]$ and $g[n]$ is a causal sequence. If $y[0] = 1$ and $y[1] = 1/2$, then $g[1]$ equals

- (A) 0
- (B) 1/2
- (C) 1
- (D) 3/2

Q.43 The state transition diagram for the logic circuit shown is

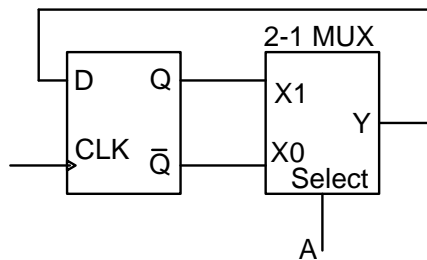

- (A)
- (B)
- (C)
- (D)

Q.44 The voltage gain A_v of the circuit shown below is

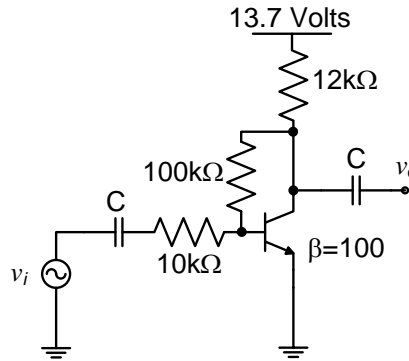

- (A) $|A_v| \approx 200$ (B) $|A_v| \approx 100$ (C) $|A_v| \approx 20$ (D) $|A_v| \approx 10$

Q.45 If $V_A - V_B = 6$ V, then $V_C - V_D$ is

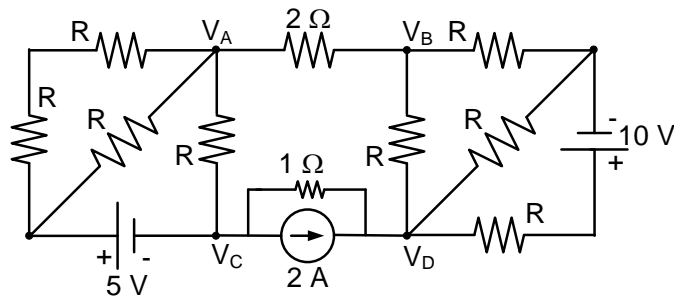

- (A) -5 V (B) 2 V (C) 3 V (D) 6 V

Q.46 The maximum value of $f(x) = x^3 - 9x^2 + 24x + 5$ in the interval $[1, 6]$ is

- (A) 21 (B) 25 (C) 41 (D) 46

Q.47 Given that

$A = \begin{bmatrix} -5 & -3 \\ 2 & 0 \end{bmatrix}$ and $I = \begin{bmatrix} 1 & 0 \\ 0 & 1 \end{bmatrix}$, the value of A^3 is

- (A) $15A + 12I$ (B) $19A + 30I$
 (C) $17A + 15I$ (D) $17A + 21I$

Common Data Questions

Common Data for Questions 48 and 49:

With 10 V dc connected at port A in the linear nonreciprocal two-port network shown below, the following were observed:

- (i) 1 Ω connected at port B draws a current of 3 A
- (ii) 2.5 Ω connected at port B draws a current of 2 A



- Q.48 With 10 V dc connected at port A, the current drawn by 7 Ω connected at port B is
 (A) 3/7 A (B) 5/7 A (C) 1 A (D) 9/7 A
- Q.49 For the same network, with 6 V dc connected at port A, 1 Ω connected at port B draws 7/3 A. If 8 V dc is connected to port A, the open circuit voltage at port B is
 (A) 6 V (B) 7 V (C) 8 V (D) 9 V

Common Data for Questions 50 and 51:

In the three dimensional view of a silicon n-channel MOS transistor shown below, $\delta = 20$ nm. The transistor is of width 1 μm . The depletion width formed at every p-n junction is 10 nm. The relative permittivities of Si and SiO_2 , respectively, are 11.7 and 3.9, and $\epsilon_0 = 8.9 \times 10^{-12}$ F/m.

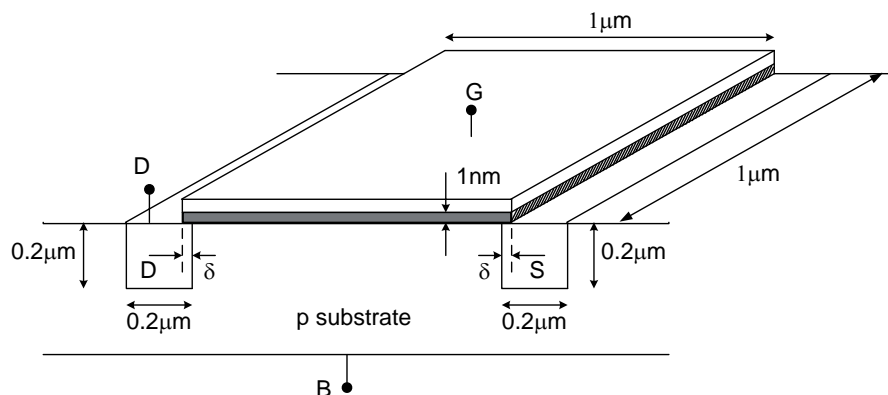

- Q.50 The gate-source overlap capacitance is approximately
 (A) 0.7 fF (B) 0.7 pF (C) 0.35 fF (D) 0.24 pF
- Q.51 The source-body junction capacitance is approximately
 (A) 2 fF (B) 7 fF (C) 2 pF (D) 7 pF

Linked Answer Questions

Statement for Linked Answer Questions 52 and 53:

An infinitely long uniform solid wire of radius a carries a uniform dc current of density \vec{j} .

Q.52 The magnetic field at a distance r from the center of the wire is proportional to

- (A) r for $r < a$ and $1/r^2$ for $r > a$ (B) 0 for $r < a$ and $1/r$ for $r > a$
 (C) r for $r < a$ and $1/r$ for $r > a$ (D) 0 for $r < a$ and $1/r^2$ for $r > a$

Q.53 A hole of radius b ($b < a$) is now drilled along the length of the wire at a distance d from the center of the wire as shown below.

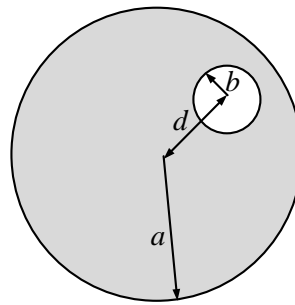

The magnetic field inside the hole is

- (A) uniform and depends only on d (B) uniform and depends only on b
 (C) uniform and depends on both b and d (D) non uniform

Statement for Linked Answer Questions 54 and 55:

The transfer function of a compensator is given as

$$G_c(s) = \frac{s+a}{s+b}$$

Q.54 $G_c(s)$ is a lead compensator if

- (A) $a=1, b=2$ (B) $a=3, b=2$
 (C) $a=-3, b=-1$ (D) $a=3, b=1$

Q.55 The phase of the above lead compensator is maximum at

- (A) $\sqrt{2}$ rad/s (B) $\sqrt{3}$ rad/s (C) $\sqrt{6}$ rad/s (D) $1/\sqrt{3}$ rad/s

General Aptitude (GA) Questions (Compulsory)**Q. 56 – Q. 60 carry one mark each.**

- Q.56 If $(1.001)^{1259} = 3.52$ and $(1.001)^{2062} = 7.85$, then $(1.001)^{3321} =$
(A) 2.23 (B) 4.33 (C) 11.37 (D) 27.64
- Q.57 Choose the most appropriate alternative from the options given below to complete the following sentence:
If the tired soldier wanted to lie down, he ___ the mattress out on the balcony.
(A) should take
(B) shall take
(C) should have taken
(D) will have taken
- Q.58 Choose the most appropriate word from the options given below to complete the following sentence:
Given the seriousness of the situation that he had to face, his ___ was impressive.
(A) beggary (B) nomenclature (C) jealousy (D) nonchalance
- Q.59 Which one of the following options is the closest in meaning to the word given below?
Latitude
(A) Eligibility (B) Freedom (C) Coercion (D) Meticulousness
- Q.60 One of the parts (A, B, C, D) in the sentence given below contains an ERROR. Which one of the following is **INCORRECT**?
I requested that he should be given the driving test today instead of tomorrow.
(A) requested that
(B) should be given
(C) the driving test
(D) instead of tomorrow

Q. 61 - Q. 65 carry two marks each.

- Q.61 **One of the legacies of the Roman legions was discipline. In the legions, military law prevailed and discipline was brutal. Discipline on the battlefield kept units obedient, intact and fighting, even when the odds and conditions were against them.**

Which one of the following statements best sums up the meaning of the above passage?

- (A) Thorough regimentation was the main reason for the efficiency of the Roman legions even in adverse circumstances.
(B) The legions were treated inhumanly as if the men were animals.
(C) Discipline was the armies' inheritance from their seniors.
(D) The harsh discipline to which the legions were subjected to led to the odds and conditions being

against them.



- Q.62 Raju has 14 currency notes in his pocket consisting of only Rs. 20 notes and Rs. 10 notes. The total money value of the notes is Rs. 230. The number of Rs. 10 notes that Raju has is
- (A) 5 (B) 6 (C) 9 (D) 10
- Q.63 There are eight bags of rice looking alike, seven of which have equal weight and one is slightly heavier. The weighing balance is of unlimited capacity. Using this balance, the minimum number of weighings required to identify the heavier bag is
- (A) 2 (B) 3 (C) 4 (D) 8
- Q.64 The data given in the following table summarizes the monthly budget of an average household.

Category	Amount (Rs.)
Food	4000
Clothing	1200
Rent	2000
Savings	1500
Other expenses	1800

The approximate percentage of the monthly budget **NOT** spent on savings is

- (A) 10% (B) 14% (C) 81% (D) 86%
- Q.65 A and B are friends. They decide to meet between 1 PM and 2 PM on a given day. There is a condition that whoever arrives first will not wait for the other for more than 15 minutes. The probability that they will meet on that day is
- (A) $1/4$ (B) $1/16$ (C) $7/16$ (D) $9/16$

END OF THE QUESTION PAPER

GATE 2012 - Answer Key - Paper : EC

Paper	Question no.	Code : A	Code : B	Code : C	Code : D
EC	1	C	A	D	B
EC	2	B	A	D	A
EC	3	C	D	B	C
EC	4	Marks to All	Marks to All	D	C
EC	5	A	B	D	A
EC	6	A	C	B	C
EC	7	B	A	A	A
EC	8	D	C	A	C
EC	9	D	A	Marks to All	B
EC	10	B	C	C	Marks to All
EC	11	D	C	B	D
EC	12	D	B	C	A
EC	13	A	C	A	A
EC	14	A	A	B	D
EC	15	D	B	C	D
EC	16	Marks to All	C	C	B
EC	17	B	Marks to All	A	D
EC	18	C	A	C	D
EC	19	A	A	A	B
EC	20	C	B	C	A
EC	21	A	D	B	A
EC	22	C	D	Marks to All	Marks to All
EC	23	C	B	D	C
EC	24	B	D	A	B
EC	25	A	D	A	C
EC	26	D	A	A	B
EC	27	B	D	C	C
EC	28	C	B	D	A
EC	29	D	Marks to All	A	D
EC	30	A	B	D	D
EC	31	C	A	C	A
EC	32	D	D	A	B
EC	33	A	D	D	Marks to All
EC	34	D	A	C	B
EC	35	A	C	B	D
EC	36	C	B	D	A
EC	37	A	D	B	C
EC	38	D	B	C	A
EC	39	B	C	A	D
EC	40	Marks to All	D	D	A



GATE 2012 - Answer Key - Paper : EC

Paper	Question no.	Code : A	Code : B	Code : C	Code : D
EC	41	B	A	D	D
EC	42	A	C	A	C
EC	43	D	D	B	A
EC	44	D	A	Marks to All	D
EC	45	A	D	B	C
EC	46	C	A	A	B
EC	47	B	C	D	D
EC	48	C	C	A	B
EC	49	C	C	B	A
EC	50	A	B	C	C
EC	51	B	A	C	C
EC	52	C	A	C	A
EC	53	A	A	A	A
EC	54	A	C	A	C
EC	55	A	A	A	A
EC	56	D	A	D	B
EC	57	A	D	B	B
EC	58	D	B	B	D
EC	59	B	B	D	A
EC	60	B	D	A	D
EC	61	A	A	A	D
EC	62	A	A	D	C
EC	63	A	D	C	A
EC	64	D	C	A	A
EC	65	C	A	A	A

